



ST. VINCENT AND THE GRENADINES

MARITIME ADMINISTRATION

CIRCULAR N° SOL 006 Rev. 11

Fire protection System and Appliances and Compressed Gas Cylinders Periodic Maintenance, Inspection and Testing

**TO: SHIPOWNERS, SHIPS' OPERATORS AND MANAGERS
FLAG STATE SURVEYORS
CLASSIFICATION SOCIETIES**

ENTRY INTO FORCE: Date of this Circular

25 May 2021

1. General

This Administration's requirements, which have been developed in line with the applicable IMO Circulars and Guidelines, are intended to establish the periodicity and extent of maintenance, inspection and testing required by the International Convention for the Safety of the Life at Sea, 1974 as amended.

This Circular applies to all ships and describes the minimum level of maintenance and inspections for fire protection systems and appliances. This information should be used as a basis for the ship's onboard maintenance plan required by SOLAS regulation II-2/14.

This Circular is developed in line with IMO MSC.1/Circ.1432 as amended by MSC.1/Circ.1516, MSC.1/Circ.1318-Rev.1 and Resolution A.951 (23).

In addition to the maintenance and inspections stated in this Circular, manufacturer's maintenance and inspection guidelines should be followed.

1.1 Operational readiness

All fire protection systems and appliances should always be in good order and readily available for immediate use while the ship is in service. If a fire protection system is undergoing maintenance, testing or repair, then suitable arrangements should be made to ensure that safety is not diminished through the provision of alternate fixed or portable fire protection equipment or other measures. The onboard maintenance plan should include provisions for this purpose.

1.2 Maintenance, Testing and Inspection

In May 2012 the IMO adopted MSC.1/Circ 1432. This replaces previous guidance from the IMO on the maintenance of fixed and portable firefighting equipment carried in ships in compliance with SOLAS.

Maintenance and inspection of fixed carbon dioxide systems or portable fire extinguishers are addressed in the MSC.1/Circ.1318-Rev.1 and the A.951 (23) respectively.

Maintenance and inspection of water mist, water spray and sprinkler systems are addressed in MSC.1/Circ.1516.

1.3 Instructions and records

Instructions for maintenance, inspections and testing of fire protection systems and appliances should be easily understood, illustrated wherever possible as appropriate and should include the following for each system or appliance:

- Inspections (weekly inspections, monthly inspections, annual inspections etc.);
- Maintenance and repair instructions;

- Schedule of periodic maintenance;
- List of replaceable parts; and
- Log and records of testing, inspections and maintenance, details of identified non-conformities and their completion dates

Records of inspections should always be maintained. The records should show the date of inspection and the type of maintenance carried out. In cases where the inspections and maintenance are carried out by an approved service company inspection reports should be provided at the completion of the testing.

Maintenance and inspection should be carried out in accordance with the ship's maintenance plan. The on-board maintenance plan should be included in the ships safety management system and should be based on the system manufacturer's recommendations.

Certain maintenance procedures and inspections may be performed by competent crewmembers, while others should be performed by an approved service company.

1.4 Approved Service Company

An approved service company means a company which is accepted, authorized, checked or inspected by the Recognized Organizations (recognized by St Vincent and The Grenadines Maritime Administration) or by other SOLAS Contracting Governments

2.MARINE PORTABLE FIRE EXTINGUISHERS

2.1 Periodical inspection and maintenance

Marine Portable Fire Extinguishers should be subject to periodical inspections in accordance with the manufacturer's instructions and serviced at intervals not exceeding one year.

Please refer to IMO Resolution A.951(23), Annex, Paragraph 9.1.3. Service and inspection should only be undertaken by, or under the supervision of a person with demonstrable competence or an approved service company, based on the inspection guide in table 9.1.3 of the Resolution A. 951(23). The competent person may be either a Senior Ship's Officer who is in possession of an Advance Fire Fighting Certificate of Proficiency (STCW A-VI/3), trained and assigned to carry out this work or an approved service company. The equipment required to test, examine, and service the fire extinguishers should be properly calibrated and in serviceable condition.

2.2 Hydrostatic Pressure Test

All non-permanently pressurized portable fire extinguishers should be hydrostatically pressure tested when found rusty but at least once in ten (10) years. Please refer to IMO Resolution A.951(23), Annex, Paragraph 9.1.2

All permanently pressurized portable fire extinguishers and propellant cartridges should be hydrostatically pressure tested at intervals not exceeding ten (10) years. Please refer to IMO Resolution A.951(23), Annex, Paragraph 9.1.2

Notwithstanding the above, whenever the loss in pressure of a permanently pressurized portable fire extinguisher exceeds 10% of the nominal pressure, then the portable fire extinguisher should be hydrostatically pressure tested before being recharged.

Hydrostatic Pressure Test should be carried out by an approved service company.

Portable fire extinguishers and propellant cartridges should be tested to the pressures indicated below.

| Portable Fire Extinguishers and Propellant Cartridges | Test Pressure |
|---|--|
| <ul style="list-style-type: none"> • Water • Foam • Dry Chemical • Halon • Powder(permanently/non-permanently pressurised) | At least 1.5 x working pressure (or 2 N/mm ² if the working pressure is unknown) |
| <ul style="list-style-type: none"> • Carbon Dioxide | At least 25 N/mm ² |
| Propellant Cartridges <ul style="list-style-type: none"> • CO₂ type with safety devices • CO₂ type without safety devices | At least 2 x working pressure 25 N/mm ² 35 N/mm ² |

2.3 Spare charges

For portable fire extinguishers of the same type capable of being recharged on board, spare charges should be provided for 100% of the first ten (10) portable extinguishers and for 50% of the remaining portable fire extinguishers. No more than a total of sixty (60) spare charges need to be provided.

For portable fire extinguishers which cannot be recharged on board, additional portable fire extinguishers of the same quantity, type and capacity should be provided for 100% of the first ten (10) portable extinguishers and for 50% of the remaining portable fire extinguishers. No more than a total of sixty (60) spare charges need to be provided. (Please refer to IMO MSC.1/Circ.847, Paragraph 6.2).

Instructions for recharging extinguishers should be supplied by the manufacturer and be available for use on board.

2.4 Annual Inspections

- Additionally, the manufacturer's requirements/instructions to the below guidance should be taken into consideration;
- Charges of portable fire extinguishers should be renewed if, on checking, there is any indication of deterioration in the contents.
- Carbon dioxide extinguishers and gas expellant cartridges should be recharged or renewed if gas loss by weight exceeds 10 % of original charge.
- Dry powder extinguishers may suffer from compaction when subject to vibration. At least one should be discharged annually and the retention of contents checked. When the retention is found to be in excess of 15% of the initial charge further extinguishers should be discharged to determine the level of compaction. If powder charges have to be used again, ensure that the powder is free flowing and that there is no evidence of caking lumps or foreign bodies.
- Water and foam charges should be moved to a clean container in order to be used again if they are suitable for further use.
- Gas cartridges should be checked for damage and corrosion.
- Any extinguisher or bottle which has excessive corrosion should be replaced.

2.5 Five Year Inspections

- At least one extinguisher of each type manufactured in the same year and kept on board a ship should be test discharged as part of a fire drill, every five (5) years.
- At each Class Renewal (not less than five (5) years) survey portable extinguishers should be inspected by an approved service company and contents changed if required.

2.6 Ten Year Inspections

- Extinguishers and propellant cartridges should be hydraulically tested in accordance with the manufacturer's instructions by an approved service company.
- Following the hydrostatic testing, a thorough inspection and internal examination should be carried out prior recharging.

3. PORTABLE FOAM APPLICATORS

3.1 Monthly Inspections

- Check that all portable foam applicators are in place, properly arranged, and in proper condition.

3.2 Annual Inspections

- Check that all portable foam applicators are set to the correct proportioning ratio for the foam concentrate supplied and that the equipment is in proper order;
- Check that all portable containers or portable tanks containing foam concentrate remain factory sealed, and that the manufacturer's recommended service life interval has not been exceeded;
- Portable containers or portable tanks containing foam concentrate, excluding protein based concentrates, less than ten (10) years old, which remain factory sealed can normally be accepted without the periodical foam control tests required in MSC.1/Circ.1312;
- Protein based foam concentrate portable containers and portable tanks should be thoroughly checked and, if more than five (5) years old, the foam concentrate should be subjected to the periodical foam control tests required in MSC.1/Circ.1312, or renewed; and
- The foam concentrates of any non-sealed portable containers, portable tanks, portable containers and portable tanks where production data is not documented, should be subjected to the periodical foam control tests required in MSC.1/Circ.1312.
- Periodical foam control test should be carried out by an approved service company.

4.WHEELED (MOBILE) FIRE EXTINGUISHERS

4.1 Monthly Inspections

- Check that all extinguishers are in place, properly arranged, and in proper condition.

4.2 Annual Inspections

- Perform periodical inspections in accordance with the manufacturer's instructions;
- Visually inspect all accessible components for proper condition;
- Check the hydrostatic test date of each cylinder; and
- For dry powder extinguishers, shake the extinguisher head down to ensure that there are no lumps in the powder.

4.3 Five (5) year Inspections

- Visually examine at least one extinguisher of each type manufactured the same year and kept on board.

4.4 Ten (10) year Inspections

All extinguishers together with propellant cartridges should be hydrostatically tested by an approved service company.

5. FIXED HIGH AND LOW CARBON DIOXIDE FIRE-EXTINGUISHING SYSTEMS

The minimum recommended level of maintenance and inspections for fixed carbon dioxide fire-extinguishing system on all ships should be carried out according to MSC.1/Circ.1318-Rev.1.

5.1 Monthly Inspections

A general visual inspection should be made of the overall system condition for obvious signs of damage and should include verification that:

- All stop valves are in the closed position;
- All releasing controls are in the proper position and readily accessible for immediate use;
- All discharge piping and pneumatic tubing is intact and has not been damaged;
- All high pressure cylinders are in place and properly secured; and
- The alarm devices are in place and do not appear damaged.

Additionally, on low pressure systems the inspections should verify that:

- The pressure gauge is reading in the normal range;
- The liquid level indicator is reading within the proper level;
- The manually operated storage tank main service valve is secured in the open position; and
- The vapour supply line valve is secured in the open position.

5.2 Annual Inspections

The following minimum level of maintenance and inspections should be carried out in accordance with the system manufacturer's instructions and safety precautions:

- The boundaries of the protected space should be visually inspected to confirm that no modifications have been made to the enclosure that have created unclose able openings that would render the system ineffective;
- All storage containers should be visually inspected for any signs of damage, rust or loose mounting hardware. Cylinders, that are leaking, corroded, dented or bulging, should be hydrostatically re-tested or replaced;
- System piping should be visually inspected to check damages, loose supports and corrosion. Nozzles should be inspected to ensure they have not been obstructed by the storage of spare parts or a new installation of structure or machinery;
- The manifold should be inspected to verify that all flexible discharge hoses and fittings are properly tightened; and
- All entrance doors to the protected space should close properly and should have warning signs, which indicate that the space is protected by a fixed carbon dioxide system and that personnel should evacuate immediately if the alarms sound. All remote releasing controls should be checked for clear operating instructions and indication as to the space served.

5.3 Biennial Inspections

At least biennially (intervals of two (2) years \pm three (3) months) in passenger ships or at each intermediate, periodical or renewal survey in cargo ships, the following maintenance should be carried out:

- All high pressure cylinders and pilot cylinders should be weighed or have their contents verified by other reliable means to confirm that the available charge in each is above 90% of the nominal charge. Cylinders containing less than 90% of the nominal charge should be re-filled. The liquid level of low pressure storage tanks should be checked to verify that the required amount of carbon dioxide to protect the largest hazard is available;
- The hydrostatic test date of all storage containers should be checked. High-pressure cylinders should be subjected to periodical tests at intervals not exceeding 10 years. At the 10-year inspection, at least 10% of the total number provided should be subjected to an internal inspection and hydrostatic test. If one or more cylinders fail, a total of 50 % of the onboard cylinders should be tested. If further cylinders fail, all cylinders should be tested. Before the 20-year anniversary and every 10-year anniversary thereafter, all cylinders should be subjected to a hydrostatic test. Flexible hoses should be replaced at the intervals recommended by the manufacturer and not exceed 10 years. When cylinders are removed for testing, the cylinders should be replaced such that the quantity of fire-extinguishing medium continues to satisfy the requirements of 2.2.1 of chapter 5 of the FSS Code, subject to SOLAS regulation II-2/14.2; and
- The discharge piping and nozzles should be tested to verify that they are not blocked. Test should be performed by isolating the discharge piping from the system and flowing dry air or nitrogen from test cylinders or suitable means through the piping;

5.4 Additional biennial Inspections and Maintenances for Passenger Vessels and five (5) year Inspections for Cargo Ships.

- At least biennially (intervals of 2 years \pm 3 months) in passenger ships or at each renewal survey in cargo ships, the following maintenance should be carried out by service technicians/ specialists trained to standards accepted by the Administration:
- Where possible, all activating heads should be removed from the cylinder valves and tested for correct functioning by applying full working pressure through the pilot lines. In cases where this is not possible, pilot lines should be disconnected from the cylinder valves and blanked off or connected together and tested with full working pressure from the release station and checked for leakage. In both cases this should be carried out from one or more release stations when installed. If manual pull cables operate the remote release controls, they should be checked to verify the cables and corner pulleys are in good condition and freely move and do not require an excessive amount of travel to activate the system;
- All cable components should be cleaned and adjusted as necessary, and the cable connectors should be properly tightened. If the remote release controls are operated by pneumatic pressure, the tubing should be checked for leakage, and the proper charge of the remote releasing station pilot gas cylinders should be verified. All controls and warning devices should function normally, and the time delay, if fitted should prevent the discharge of gas for the required time period; and
- After completion of the work, the system should be returned to service. All releasing controls should be verified in the proper position and connected to the correct control valves. All pressure switch interlocks should be reset and returned to service. All stop valves should be in the closed position.

5.5 Five (5) year service

- At least once every five years, internal inspection of all control valves should be performed.

6. FIXED GAS (EXCEPT CARBON DIOXIDE) FIRE-EXTINGUISHING SYSTEMS

6.1 Weekly Inspections

- Verify all fixed fire-extinguishing system control panel indicators are functional by operating the lamp/indicator test switch; and
- Verify all control/section valves are in the correct position.

6.2 Monthly Inspection

- Verify containers/cylinders fitted with pressure gauges are in the proper range and the installation free from leakage

6.3 Annual Inspection

- Visually inspect all accessible components for proper condition;
- Externally examine all high pressure cylinders for evidence of damage or corrosion;
- Check the hydrostatic test date of all storage containers;
- Functionally test all fixed system audible and visual alarms;
- Verify all control/section valves are in the correct position;
- Check the connections of all pilot release piping and tubing for tightness;

- Examine all flexible hoses in accordance with manufacturer's recommendations;
- Test all fuel shut-off controls connected to fire-protection systems for proper operation;
- The boundaries of the protected space should be visually inspected to confirm that no modifications have been made to the enclosure that have created enclosable openings that would render the system ineffective; and
- If cylinders are installed inside the protected space, verify the integrity of the double release lines inside the protected space, and check low pressure or circuit integrity monitors on release cabinet, as applicable.

6.4 Biennial inspections

- All high pressure extinguishing agents cylinders and pilot cylinders should be weighed or have their contents verified by other reliable means to confirm that the available charge in each is above 95 per cent of the nominal charge. Cylinders containing less than 95 per cent of the nominal charge should be refilled; and
- Blow dry compressed air or nitrogen through the discharge piping or otherwise confirm the pipe work and nozzles are clear of any obstructions. This may require the removal of nozzles, if applicable.

6.5 Five (5) year Inspection

- Perform internal inspection of all control valves by an approved service company.

6.6 Ten (10) year Inspection

- Perform a hydrostatic test and internal examination of 10 per cent of the system's extinguishing agent and pilot cylinders. If one or more cylinders fail, a total of 50 per cent of the onboard cylinders should be tested. If further cylinders fail, all cylinders should be tested;

The above should be carried out by an approved service company

Flexible hoses should be replaced at the intervals recommended by the manufacturer and not exceeding every ten (10) years.

7. FIXED DRY CHEMICAL POWDER FIRE-EXTINGUISHING SYSTEM

7.1 Monthly Inspections

Verify that all control and section valves are in the proper open or closed position, and all pressure gauges are in the proper range.

7.2 Annual Inspections

- Visually inspect all accessible components for proper condition;
- Verify that the pressure regulators are in proper order and within calibration; and
- Mix the dry chemical powder charge with nitrogen in accordance with system manufacturer's instructions. (**Note:** Due to the powder's affinity for moisture, any nitrogen gas introduced for mixing should be moisture free.)

7.3 Biennial Inspections

- Blow dry nitrogen through the discharge piping to confirm that the pipe work and nozzles are clear of any obstructions;
- Operationally test local and remote controls and section valves;
- Verify the contents of propellant gas cylinders (including remote operating stations);
- Test a sample of dry chemical powder for moisture content; and
- Subject the powder containment vessel, safety valve and discharge hoses to a full working pressure test.

The above inspection should be carried out by an approved service company. Testing of dry powder sample for moisture absorption should be carried out at the same interval.

7.4 Ten (10) year Inspections

Subject all powder containment vessels to hydrostatic or non-destructive testing carried out by an approved service company.

8. FIXED AEROSOL EXTINGUISHING SYSTEM

8.1 Monthly Inspections

- Verify all electrical connections and/or manual operating stations are properly arranged, and are in proper condition; and
- Verify that the actuation system/control panel circuits are within manufacturer's specifications.

8.2 Annual Inspection

Verify that condensed or dispersed aerosol generators have not exceeded their mandatory replacement date. Pneumatic or electric actuators should be demonstrated working, as far as practicable.

8.3 Ten (10) year Inspections

Condensed or dispersed aerosol generators should be renewed in accordance with manufacturer's recommendations by an approved service company.

9. FIXED FOAM FIRE-EXTINGUISHING SYSTEM

9.1 Monthly Inspections

Verify all control and section valves are in the proper open or closed position, and all pressure gauges are in the proper range.

9.2 Quarterly Inspections

Verify the proper quantity of foam concentrate is provided in the foam system storage tank.

9.3 Annual Inspections

- Visually inspect all accessible components for proper condition;
- Functionally test all fixed system audible alarms;
- Flow test all water supply and foam pumps for proper pressure and capacity, and confirm flow at the required pressure in each section (ensure all piping is thoroughly flushed with fresh water after service.)
- Test all system cross connections to other sources of water supply for proper operation;
- Verify all pump relief valves, if provided, are properly set;
- Examine all filters/strainers to verify that they are free of debris and contamination;
- Verify that all control/section valves are in the correct position;
- Blow dry compressed air or nitrogen through the discharge piping or otherwise confirm the pipework and nozzles of high expansion foam systems are clear of any obstructions, debris and contamination. This may require the removal of nozzles, if applicable;
- Take samples from all foam concentrates carried on board and subject them to the periodical control tests in MSC.1/Circ.1312, for low expansion foam, or MSC/Circ.670 for high expansion foam by an approved service company; (**Note:** Except for non-alcohol resistant foam, the first test does not need to be conducted until three (3) years after being supplied to the ship.) and
- Test all fuel shut-off controls connected to fire-protection systems for proper operation.

9.4 Five (5) year Inspections

- Perform internal inspection of all control valves by an approved service company;
- Flush all high expansion foam system piping with fresh water, drain and purge with air;
- Check all nozzles to prove they are clear of debris; and
- Test all foam proportioners or other foam mixing devices to confirm that the mixing ratio tolerance is within +30 to -10% of the nominal mixing ratio defined by the system approval.

9.5 Foam sample Analysis

Notwithstanding the above-mentioned, occasional foam analysis may be requested at the discretion of the attending surveyor from the Recognized Organization during statutory surveys if there is cause to question the suitability of the foam.

10. FIXED HALON FIRE-EXTINGUISHING SYSTEM

10.1 General

Halon is not accepted as a fire-extinguishing means on board any ship applying for registration under the St Vincent and The Grenadines Flag since 1st January 2002. Alternative arrangements for Halon Fire-Extinguishing System in machinery spaces and pump room (MSC/Circ. 668) have to be fitted. Fixed Halon Fire-Extinguishing System will be replaced either by CO₂ other suitable fire-extinguishing system if a major refit is undertaken.

10.2 Hydrostatic Pressure Test or Thickness Measurement for existing fixed Halon fire-extinguishing system.

Subject to the ready availability of Halon Banking facilities for the purpose of containment and recharging, over a maximum period of ten (10) years at least 50% of the Halon bottles should be tested by hydraulic pressure by an approved service company.

Over a maximum period of twenty (20) years, 100% of the Halon bottles should be tested by hydraulic pressure by an approved service company.

However, when Halon Banking facilities are unavailable, Halon cylinders should be subject to thickness measurement in lieu of the hydrostatic pressure test as required above. At least 50% of the cylinders should be thickness measured over a period of ten (10) years.

Over a maximum period of twenty (20) years, 100% of the Halon bottles should be thickness measured.

Notwithstanding the above-mentioned, occasional hydrostatic pressure testing or thickness measurement, as applicable, may be requested at the discretion of the attending Class Surveyor conducting the statutory surveys if evidence exists to cause concern on the condition of the cylinders.

11. WATER-MIST WATER-SPRAY AND SPRINKLER SYSTEMS

11.1 General

The quality of the water in the automatic sprinkler systems is of particular importance and should be maintained in accordance with manufacturer guidelines. Records of water quality should be maintained on board in accordance with the manufacturer's guidelines.

11.2 Weekly Inspections

- Verify all control panel indicators and alarms are functional;
- Visually inspect pump unit and its fittings; and
- Check the pump unit valve positions, if valves are not locked, as applicable.

11.3 Monthly Inspections

- Verify all control, pump unit and section valves are in the proper open or closed position;
- Verify sprinkler pressure tanks or other means have correct levels of water;
- Test automatic starting arrangements on all system pumps so designed;
- Verify all standby pressure and air/gas pressure gauges are within the proper pressure ranges; and
- Test a selected sample of system section valves for flow and proper initiation of alarms. (**Note** – The valves selected for testing should be chosen to ensure that all valves are tested within a one (1) year period.)

11.4 Quarterly Testing and Inspection

- Assess system water quality in the header tank and pump unit against the manufacturer's water quality guidelines.

11.5 Annual Inspections

- Verify proper operation of all water mist, water-spray and sprinkler systems using the test valves for each section;
- Visually inspect all accessible components for proper condition;
- Externally examine all high pressure cylinders for evidence of damage or corrosion;
- Check the hydrostatic test date of all high pressure cylinders;
- Functionally test all fixed system audible and visual alarms;
- Flow test all pumps for proper pressure and capacity;
- Test all antifreeze systems for adequate freeze protection;
- Test all system cross connections to other sources of water supply for proper operation;
- Verify all pump relief valves, if provided, are properly set;
- Examine all filters/strainers to verify they are free of debris and contamination;
- Verify all control/section valves are in the correct position;
- Blow dry compressed air or nitrogen through the discharge piping of dry pipe systems, or otherwise confirm the pipework and nozzles are clear of any obstructions. This may require the removal of nozzles, if applicable;
- Test emergency power supply switchover, where applicable;

- Visually inspect all sprinklers focusing in areas where sprinklers are subject to aggressive atmosphere (like saunas, spas, kitchen areas) and subject to physical damage (like luggage handling areas, gyms, play rooms, etc.) so that all sprinklers are inspected in one year. Sprinklers with obvious external damage, including paint, should be replaced and not included in the number of sprinklers tested in accordance with the flow charts Part 1 – Basic Testing and Part 2 – Extended Testing as indicated in MSC.1/Circ.1516 annexed to this circular;
- Check for any changes that may affect the system such as obstructions by ventilation ducts, pipes, etc.;
- Test a minimum of one section in each open head water mist system by flowing water through the nozzles. The sections tested should be chosen so that all sections are tested within a five (5) year period; and
- Test automatic sprinklers and automatic water mist nozzles in accordance with the flow charts Part 1 – Basic Testing and Part 2 – Extended Testing as indicated in MSC.1/Circ.1516 annexed to this circular.

11.6 Five (5) year Inspections

- Flush all ro-ro deck deluge system piping with water, drain and purge with air;
- Perform internal inspection of all control/section valves;
- Check condition of any batteries, or renew in accordance with manufacturer's recommendations;

This inspection should be carried out by an approved service company.

11.7 Ten (10) year Inspection

- Hydrostatic test and internal examination by an approved service company for gas and water pressure cylinders should be carried out in accordance with EN 1968:2002 + A1.

12. SELF-CONTAINED BREATHING APPARATUS (SCBA)

12.1 Weekly Inspections

A general examination of all breathing apparatus, including cylinder gauges to confirm they are in the correct pressure range.

12.2 Annual Inspections

- check breathing apparatus air recharging systems, if fitted, for air quality;
- check all breathing apparatus face masks and air demand valves are in serviceable condition; and
- check SCBA according to maker's instruction

Note: On Chemical Tankers and Gas Tankers SCBA **should** be inspected and tested annually by an approved service company

12.3 Five (5) year Inspections

- Hydrostatic pressure testing of cylinders of lightweight type should be carried out by an approved service company at intervals and test pressure stipulated by the manufacturer and Recognized Organization.
- Hydrostatic pressure testing of cylinders other than of lightweight type should be carried out every five (5) years by an approved service company at a test pressure of 1.5 times the working pressure.

12.4 Spare charges

The following number of spare charges should be provided for each breathing apparatus:

| Ship type | Spare charges |
|---|----------------------|
| Cargo Ship without dedicated cylinder recharging facility | 2 |
| Cargo Ship with dedicated cylinder recharging facility | 1 |
| Passenger ship carrying less than 36 passengers | 1 |
| Passenger ship carrying more than 36 passengers | At least 2 |

13. EMERGENCY ESCAPE BREATHING DEVICE (EEBD)

13.1 Weekly Inspections

Examine all breathing apparatus and EEBD cylinder gauges to confirm they are in the correct pressure range.

13.2 Annual Inspections

Check EEBDs according to manufacturer's instructions.

Note: Hydrostatic Test and internal inspection of cylinders if required by the manufacturer should be in compliance. EEBD which have exceeded their service life as indicated by the manufacturer should be discarded.

14. GALLEY DEEP FAT COOKING FIRE-EXTINGUISHING SYSTEMS

14.1 Annual Inspections

Check galley and deep fat cooking fire-extinguishing systems in accordance with the manufacturer's instructions.

15. PUBLIC ADDRESS AND GENERAL ALARM SYSTEM

15.1 Weekly Inspections

Verify all public address systems and general alarm systems are functioning properly.

16. FIRE DOORS

16.1 Weekly Inspections

Verify all fire door control panel indicators, if provided, are functional by operating the lamp/indicator switch.

16.2 Quarterly Inspections

Test all fire doors located in main vertical zone bulkheads for local operation.

16.3 Annual Inspections

Test all remotely controlled fire doors for proper release.

17. FIXED FIRE DETECTION AND ALARM SYSTEMS

17.1 Weekly Inspections

- Verify that all fire detection and fire alarm control panel indicators are functional by operating the lamp/indicator test switch.
- Verify that all control/section valves are in the correct position.

17.2 Monthly Inspections

Test a sample of detectors and manual call points so that all devices have been tested within five years.

17.3 Annual Inspections

- Test that all fire detection systems and fire detection systems are used to automatically release fire extinguishing systems for proper operation, as appropriate;
- Visually inspect all accessible detectors for evidence of tampering obstruction, etc., so that all detectors are inspected within one year; and
- Test emergency power supply switchover.

18. VENTILATION SYSTEMS AND FIRE DAMPERS

18.1 Quarterly Inspections

Test all fire dampers for local operation.

18.2 Annual Inspections

- Test all fire dampers for remote operation;
- Verify that galley exhaust ducts and filters are free of grease build-up; and
- Test that all ventilation controls interconnected with fire-protection systems are for proper operation.

19. FIRE MAINS, FIRE PUMPS, HYDRANTS, HOSES AND NOZZLES

19.1 Monthly Inspections

- Verify that all fire hydrants, hose and nozzles are in place, properly arranged, and in serviceable condition;
- Operate all fire pumps to confirm that they continue to supply adequate pressure; and
- Emergency fire pump fuel supply adequate and heating system in satisfactory condition, if applicable.

19.2 Quarterly Inspections

Verify that the international shore connection(s) is in serviceable condition.

19.3 Annual Inspections

- Visually inspect all accessible components for proper condition;
- Flow test all fire pumps for proper pressure and capacity. Test emergency fire pump with isolation valves closed;
- Test all hydrant valves for proper operation;
- Pressure test a sample of fire hoses at the maximum fire main pressure, so that all fire hoses are tested within five years;
- Verify that all fire pump relief valves, if provided, are properly set;
- Examine all filters/strainers to verify that they are free of debris and contamination; and
- Nozzle size/type correct, maintained and working.

20. FIREMAN'S OUTFIT

Monthly Inspections

Verify that lockers providing storage for fire-fighting equipment contain their full inventory and that the equipment is in serviceable condition.

21. OXYGEN CYLINDERS FOR MEDICAL USE

21.1 General

The vessels falling under Column A or B of the Medical First Aid Guide (MFAG) Appendix 14 – List of Equipment, are required to carry medical oxygen. MFAG should be used in conjunction with the information provided in the IMDG Code, the IMSBC Code, the Emergency Procedures for Ships Carrying Dangerous Goods (EmS), IBC Code and IGC Code.

21.2 Annual Testing and Inspections

Cylinders should be inspected annually by an authorized servicing company. Alternatively, annual inspection may be carried out on board by a Senior Ship's Officer provided that the manufacturer's instructions are available on board and followed.

21.3 Three (3) year Testing and Inspections

- Cylinders should be re-charged with medical oxygen at intervals not exceeding three (3) years but ~~in any case~~ prior to the stipulated expiry date. In case the loss of contents of the system as a whole or of an individual part or unit of the system exceeds 10 %, the system or the individual part or unit of the system should be recharged.
- Pressure pipes connecting the cylinder to the regulator should be subject to a pressure test every three (3) years or at more frequent intervals if so advised by the manufacturer.

The above testing and inspection should be carried out by an authorized servicing company.

21.4 Five (5) year Testing and Service

- Hydrostatic pressure testing of cylinders should be carried out every five (5) years or at more frequent intervals if so advised by the manufacturer.
- Pressure regulators should be serviced at least every five (5) years.

The above testing and service should be carried out by an authorized servicing company.

Annexes to this circular:

MSC/Circ.1432, A.951(23), MSC/Circ.670, MSC/Circ.798, MSC.1/Circ.847, MSC.1/Circ.849, MSC.1/Circ.1312, MSC.1/Circ.1312/Corr.1, MSC.1/Circ.1318-Rev.1, MSC.1/Circ.1516

Revision History: Rev 10; Paragraphs: 1, 1.2, 11.1(added), 11.4(added), 11.5, 21 (added), Annexes Rev 11; Paragraphs: 5, 5.2, 5.3, 5.4, 5.5, Annexes

| | |
|--------------|---|
| Title | MSC Circulars / MSC.1/Circ.1312 |
| Note | Supersedes MSC/Circ.582, MSC/Circ.582/Corr.1 and MSC/Circ.799 |

MSC.1/Circ.1312

10 June 2009

REVISED GUIDELINES FOR THE PERFORMANCE AND TESTING CRITERIA, AND SURVEYS OF FOAM CONCENTRATES FOR FIXED FIRE- EXTINGUISHING SYSTEMS

- 1 The Maritime Safety Committee, at its sixtieth session (6 to 10 April 1992), approved Guidelines for the performance and testing criteria, and surveys of low-expansion foam concentrates for fixed fire-extinguishing systems (MSC/Circ.582).
- 2 The Committee, at its sixty-eighth session (28 May to 6 June 1997), approved Guidelines for the performance and testing criteria, and surveys of expansion foam concentrates for fixed fire-extinguishing systems of chemical tankers (MSC/Circ.799).
- 3 The Sub-Committee on Fire Protection, at its fifty-third session (16 to 20 February 2009) reviewed the aforementioned Guidelines and made amendments to the test methods for both types of foam concentrates which combined the test procedure into one document.
- 4 The Committee, at its eighty-sixth session (27 May to 5 June 2009), after having considered the above proposal by the Sub-Committee on Fire Protection, at its fifty-third session, approved the Revised Guidelines for the performance and testing criteria, and surveys of foam concentrates for fixed fire-extinguishing systems, as set out in the annex.
- 5 Member Governments are invited to apply the annexed Guidelines when approving foam concentrates for fixed fire-extinguishing systems onboard tankers and chemical tankers and bring them to the attention of ship designers, shipowners, equipment manufacturers, test laboratories and other parties concerned.
- 6 This circular supersedes [MSC/Circ.582](#) and [Corr.1](#), and [MSC/Circ.799](#). Type approvals conducted in accordance with the aforementioned Guidelines should remain valid until 1 July 2012.

ANNEX

REVISED GUIDELINES FOR THE PERFORMANCE AND TESTING CRITERIA, AND SURVEYS OF FOAM CONCENTRATES FOR FIXED FIRE-EXTINGUISHING SYSTEMS

1 GENERAL

1.1 Application

These Guidelines apply to the foam concentrates used for fixed deck foam fire-extinguishing systems required for tankers by SOLAS regulations II-2/10.8 and chapter 14 of the International Code for Fire Safety Systems (FSS Code), and chemical tankers as specified by SOLAS regulation II-2/1.6.2.1.2 and the International Code for the Construction and Equipment of Ships Carrying Dangerous Chemicals in Bulk (IBC Code). These Guidelines also apply to foam concentrates for fixed foam fire-extinguishing systems in machinery spaces according to chapter 6 of the FSS Code and to portable foam applicators according to chapter 4 of the FSS Code. These Guidelines do not apply to the foam generating equipment, only the foam concentrate.

1.2 Definitions

Disclaimer : Although all possible efforts have been made to ensure correctness and completeness of the information contained in this Web Service, the Korean Register of Shipping is not responsible for any errors or omissions made herein, nor held for any actions taken by any party as a result of information retrieved from this Web Service.

E-mail : krcon@krs.co.kr

| | |
|--------------|---|
| Title | MSC Circulars / MSC.1/Circ.1312 |
| Note | Supersedes MSC/Circ.582, MSC/Circ.582/Corr.1 and MSC/Circ.799 |

For the purpose of these Guidelines, the following definitions apply:

- 1.2.1 Foam (fire fighting) is an aggregate of air filled bubbles formed from an aqueous solution of suitable foam concentrate.
- 1.2.2 Foam solution is a solution of foam concentrate and water.
- 1.2.3 Foam concentrate is a liquid which, when mixed with water in the appropriate concentration, gives a foam solution.
- 1.2.4 Expansion ratio is the ratio of the volume of foam to the volume of foam solution from which it was made.
- 1.2.5 Spreading coefficient is a measurement of the ability of one liquid to spontaneously spread across another.
- 1.2.6 25% (50%) drainage time is the time for 25% (50%) of the liquid content of a foam to drain out.
- 1.2.7 Gentle application is the application of foam to the surface of a liquid fuel via a backboard, tank wall or surface.
- 1.2.8 Sediment is insoluble particles in the foam concentrate.
- 1.2.9 Aqueous film-forming foam concentrate (AFF) is a foam concentrate based on a mixture of hydrocarbon and fluorinated surface active agents.
- 1.2.10 Alcohol-resistant foam concentrate (AR) is a foam concentrate that is resistant to breakdown when applied to the surface of alcohol or other polar solvents.
- 1.2.11 Film-forming fluoroprotein foam concentrate (FFFP) is a foam concentrate which has the ability to form an aqueous film on the surface of some hydrocarbons.
- 1.2.12 Fluoroprotein foam concentrate (FP) is a protein foam concentrate with added fluorinated surface active agents.
- 1.2.13 Protein foam concentrate (P) is a foam concentrate made from hydrolyzed protein materials.
- 1.2.14 Synthetic foam concentrate (S) is a foam concentrate based on a mixture of hydrocarbon surface active agents and which may contain fluorocarbons with additional stabilizers.
- 1.2.15 Type A foam concentrates are alcohol-resistant or multi-purpose foam concentrates.
- 1.2.16 Type B foam concentrates are all regular type foam concentrates that are not alcohol-resistant, including fluoroprotein and aqueous film-forming (AFF) foam concentrates.

2 SAMPLING PROCEDURE

The sampling method should ensure representative samples which should be stored in filled containers.

The sample size should be:

- .1 2 x 20 l containers (or other standard shipping containers) for type tests (see section 3); and
- .2 2 l for periodical controls (see section 4).

3 TESTS FOR TYPE APPROVAL OF FOAM CONCENTRATES

For foam concentrate type approval, the tests under paragraphs 3.1 to 3.14 below should be performed by the foam concentrate manufacturer at laboratories acceptable to the Administration.

3.1 Freezing and thawing

- 3.1.1 Before and after temperature conditioning in accordance with paragraph 3.1.2 below, the foam concentrate should show no visual sign of stratification, non-homogeneity or sedimentation.

Disclaimer : Although all possible efforts have been made to ensure correctness and completeness of the information contained in this Web Service, the Korean Register of Shipping is not responsible for any errors or omissions made herein, nor held for any actions taken by any party as a result of information retrieved from this Web Service.

E-mail : krcon@krs.co.kr

| | |
|--------------|---|
| Title | MSC Circulars / MSC.1/Circ.1312 |
| Note | Supersedes MSC/Circ.582, MSC/Circ.582/Corr.1 and MSC/Circ.799 |

3.1.2 Freezing and thawing test:

.1 apparatus:

- .1 freezing chamber, capable of achieving temperatures required, as stated in paragraph 3.1.2.2.1 below;
- .2 polyethylene tube, approximately 10 mm diameter, 400 mm long and sealed and weighted at one end, with suitable spacers attached. Figure 1 shows a typical form; and
- .3 500 ml cylinder, approximately 400 mm high and 65 mm in diameter.

.2 procedure:

- .1 set the temperature of the freezing chamber to a temperature which is 10°C below the freezing point of the sample measured in accordance with standard BS 5117, section 1.3 (excluding 5.2 in the standard). To prevent the glass measuring cylinder from breaking, due to expansion of the foam concentrate on freezing, insert the tube into the measuring cylinder, sealed end downward, weighted if necessary to avoid flotation, and the spacers ensuring it remains approximately on the central axis of the cylinder. Place the cylinder with the sample in the chest, cool it and maintain at the required temperature for 24 h. At the end of this period, thaw the sample for not less than 24 h and not more than 96 h in an ambient temperature of 20 to 25°C;
- .2 repeat the procedure described in the above subparagraph three times to give four cycles of freezing and thawing; and
- .3 condition the sample for seven days at 60°C followed by one day at room temperature. The sample shall then be examined for visual signs of stratification, non-homogeneity or sedimentation.

3.2 Heat stability

An unopened 20 l container (or other standard shipping container), as supplied by the manufacturer from a production batch, should be maintained for seven days at 60°C, followed by one day at room temperature. Following this conditioning, the foam liquid after agitating/stirring will be subjected to the fire test as per subsection 3.9. Only fire tests as per subsection 3.9 should be performed with the heat conditioned sample.

3.3 Sedimentation

3.3.1 Any sediment in the concentrate prepared in accordance with section 2 should be dispersible through a 180 µm sieve, and the percentage volume of sediment should not be more than 0.25% when tested in accordance with paragraph 3.3.2 below.

3.3.2 The test should be carried out as follows:

.1 apparatus:

- .1 graduated centrifuge tubes;
- .2 centrifuge operating at 6,000 ± 100 m/s²;
- .3 180 µm sieve complying with standard ISO 3310-1; and
- .4 plastic wash bottle.

Note: a centrifuge and tubes complying with standard ISO 3734 are suitable; and

.2 procedure: centrifuge each sample for 10 min. Determine the volume of the sediment and determine the percentage of this volume with respect to the centrifuged sample volume. Wash the contents of the centrifuge tube onto the sieve and check that the sediment can or cannot be dispersed through the sieve by the jet from the plastic wash bottle.

Note: It is possible that the test method is not suitable for some non-Newtonian foam concentrates. In this case an alternative method, to the satisfaction of the Administration, should be used so that compliance with this requirement can be verified.

| | |
|--------------|---|
| Title | MSC Circulars / MSC.1/Circ.1312 |
| Note | Supersedes MSC/Circ.582, MSC/Circ.582/Corr.1 and MSC/Circ.799 |

3.4 Kinematic viscosity

3.4.1 The test should be carried out according to standard ASTM D 445-86 or ISO 3104. Kinematic viscosity should not exceed 200 mm²/s.

3.4.2 The method for determining viscosity of non-Newtonian foam concentrates or kinematic viscosity exceeding 200 mm²/s should be to the satisfaction of the Administration. A suitable method is described in standard EN 1568.

3.5 pH value

The pH of the foam concentrate prepared in accordance with section 2 should be not less than 6 and not more than 9.5 at 20 ± 2°C.

3.6 Film formation of the foam solution (if applicable)

3.6.1 The spreading coefficient should be determined using the following formula:

$$S = T_c - T_s - T_i$$

where:

S is the spreading coefficient;

T_c is the surface tension of cyclohexane (N/m);

T_s is the surface tension of the foam solution (N/m);

T_i is the interfacial tension between the foam solution and cyclohexane (N/m).

T_c, T_s and T_i should be determined according to paragraph 3.6.2 below.

The spreading coefficient S should be greater than 0.

3.6.2 Determination of T_c, T_s and T_i

.1 materials:

.1 solution of foam concentrate, at the recommended usage concentration in distilled water complying with standard ISO 3696; and

Note: The solution may be made up in a 100 ml volumetric flask using a pipette to measure the foam concentrate.

.2 for T_c and T_i, cyclohexane of purity not less than 99%;

.2 procedures for surface tension: determine T_s at a temperature of 20 ± 2°C using the ring or plate method of standard ISO 304; and

.3 procedure for interfacial tension: after measuring the surface tension in accordance with subparagraph .2 above, introduce a layer of cyclohexane at 20 ± 2°C onto the foam solution, being careful to avoid contact between the ring or plate and the cyclohexane. Wait 6 ± 1 min and measure T_i.

3.7 Expansion ratio

3.7.1 The test should be carried out according to paragraph 3.7.2 with simulated seawater at about 20°C having the characteristics stated in paragraph 3.7.3.

3.7.2 Determination of the expansion ratio

.1 apparatus:

.1 plastic collecting vessel of volume V, known to ± 16 ml, as shown in figure 2, equipped with a bottom discharge facility;

.2 foam collector, as shown in figure 3; and

Disclaimer : Although all possible efforts have been made to ensure correctness and completeness of the information contained in this Web Service, the Korean Register of Shipping is not responsible for any errors or omissions made herein, nor held for any actions taken by any party as a result of information retrieved from this Web Service.

E-mail : krcon@krs.co.kr

| | |
|--------------|---|
| Title | MSC Circulars / MSC.1/Circ.1312 |
| Note | Supersedes MSC/Circ.582, MSC/Circ.582/Corr.1 and MSC/Circ.799 |

.3 foam making equipment with nozzle, as shown in figure 4, which when tested with water has a flow rate of 11.4 l/min at a nozzle pressure of 6.3 ± 0.3 bar;

.2 procedure:

.1 check that the pipe work and hose from the foam solution tank to the nozzle is completely full of solution. Set up the nozzle horizontally directly in front of the foam collector with the front of the nozzle 3 ± 0.3 m from the top edge of the collector. Wet the vessel internally and weigh it (W_1). Set up the foam equipment and adjust the nozzle pressure to give a flow rate of 11.4 l/min. Discharge the foam and adjust the height of the nozzle so that the discharge strikes the collector centrally. Keep the nozzle horizontal. Stop the foam discharge and rinse all foam from the collector. Check that the foam solution tank is full. Start discharging the foam and after 30 ± 5 s to allow the discharge to stabilize, place the collecting vessel, with the discharge outlet closed, on the collector. As soon as the vessel is full, remove it from the collector, strike the foam surface level with the rim and start the clock. Weigh the vessel (W_2);

.2 calculate the expansion E from the equation:

in which it is assumed that the density of the foam solution is 1 and where:

V is the vessel volume in ml;

W_1 is the mass of the empty vessel in grams;

W_2 is the mass of the full vessel in grams; and

.3 open the drainage facility and collect the foam solution in the measuring cylinder to measure the 25% drainage time (see paragraph 3.8.1 below).

3.7.3 Simulated sea water may be made up by dissolving in 0.9584 kg of potable water:

| | | |
|-------|--------------------|---|
| 25 g | Sodium chloride | (NaCl); |
| 11 g | Magnesium chloride | (MgCl ₂ 6 H ₂ O); |
| 1.6 g | Calcium chloride | (CaCl ₂ 2H ₂ O); |
| 4 g | Sodium sulphate | (Na ₂ SO ₄). |

3.8 Drainage time

3.8.1 The drainage time should be determined according to paragraph 3.7.2.3 above, after having determined the expansion ratio.

3.8.2 The test should be carried out with simulated seawater at about 20°C having the characteristics stated in paragraph 3.7.3 above.

3.9 Fire tests

Fire tests should be carried out according to paragraphs 3.9.1 to 3.9.7.

Note: The fire tests of this subsection 3.9 are more expensive and time consuming than the other tests of these Guidelines. It is recommended that fire tests should be carried out at the end of the test programme, so as to avoid the expense of unnecessary testing of foam concentrates which do not comply in other respects.

3.9.1 Environmental conditions:

.1 air temperature $15 \pm 5^\circ\text{C}$;

.2 fuel temperature $17.5 \pm 2.5^\circ\text{C}$;

Disclaimer : Although all possible efforts have been made to ensure correctness and completeness of the information contained in this Web Service, the Korean Register of Shipping is not responsible for any errors or omissions made herein, nor held for any actions taken by any party as a result of information retrieved from this Web Service.

E-mail : krcon@krs.co.kr

| | |
|--------------|---|
| Title | MSC Circulars / MSC.1/Circ.1312 |
| Note | Supersedes MSC/Circ.582, MSC/Circ.582/Corr.1 and MSC/Circ.799 |

- .3 water temperature $17.5 \pm 2.5^{\circ}\text{C}$;
- .4 foam solution temperature $17.5 \pm 2.5^{\circ}\text{C}$; and
- .5 maximum wind speed 3 m/s in proximity of the fire tray.

Note: If necessary, some form of wind-screen may be used.

3.9.2 Observations during the fire test:

During the fire test, record the following:

- .1 indoor or outdoor test;
- .2 air temperature;
- .3 fuel temperature;
- .4 water temperature;
- .5 foam solution temperature;
- .6 wind speed;
- .7 extinction time; and
- .8 25% burnback time.

Note: Burnback time may either be determined visually by an experienced person or may be determined from thermal radiation measurements (a suitable method is described in standard EN 1568).

3.9.3 Foam solution:

- .1 prepare a foam solution following the recommendations from the supplier for concentration, maximum premix time, compatibility with the test equipment, avoiding contamination by other types of foam, etc; and
- .2 the test should be carried out with simulated sea water at about 20°C having the characteristics stated in paragraph 3.7.3 above.

3.9.4 Apparatus:

.1

fire tray: square tray with the following dimensions:

- area 4.5 m^2 ;
- depth 200 mm;
- thickness of steel wall 2.5 mm;

with a vertical steel backboard $1 \pm 0.05 \text{ m}$ high and $1 \pm 0.05 \text{ m}$ long;

.2 foam making equipment: in accordance with paragraph 3.7.2.1 for type B foam concentrates. For type A foam concentrates, the foam application rate should be as determined by the manufacturer, up to a total of three nozzles in accordance with paragraph 3.7.2.1;

.3

burnback pot: circular burnback pot with the following dimensions:

- diameter $300 \pm 5 \text{ mm}$;
- height $150 \pm 5 \text{ mm}$;
- thickness of steel wall 2.5 mm.

| | |
|--------------|---|
| Title | MSC Circulars / MSC.1/Circ.1312 |
| Note | Supersedes MSC/Circ.582, MSC/Circ.582/Corr.1 and MSC/Circ.799 |

3.9.5 Fuel

3.9.5.1 For type B foams, use an aliphatic hydrocarbon mixture with physical properties according to the following specification:

- distillation range 84°C to 105°C;
- maximum difference between initial and final boiling points 10°C;
- maximum aromatic content 1%;
- density at 15°C $707.5 \pm 2.5 \text{ kg/m}^3$;
- temperature about 20°C.

Note: Typical fuels meeting this specification are n-heptane and certain solvent fractions sometimes referred to as commercial heptane.

The Administration may require additional fire tests using an additional test fuel.

3.9.5.2 For type A foams, acetone and isopropyl alcohol should be used as the standard test fuels. However, the Administration may require additional fire tests using different test fuels for water-miscible cargoes that require a higher foam application rate than acetone. Impurities for all type A fuels should not exceed 1%.

3.9.6 Test procedure:

.1 place the tray directly on the ground and ensure that it is level. If using heptane, add approximately 90 l of simulated sea water having the characteristics stated in paragraph 3.7.3, and check that the base of the tray is completely covered. Set up the foam nozzle horizontally, about 1 m above the ground in a position where the central part of the foam discharge will strike the centre axis of the backboard, $0.35 \pm 0.1 \text{ m}$ above the rim of the tray (gentle application). Add $144 \pm 5 \text{ l}$ of fuel, to give a nominal freeboard of 150 mm. If using acetone or isopropyl alcohol, add $234 \pm 5 \text{ l}$ of fuel directly into the tray, without water, to give a nominal freeboard of 150 mm;

.2 ignite the tray not more than 5 min after adding the fuel and allow it to burn for a period of $60 \pm 5 \text{ s}$ after full involvement of the surface of the fuel, then start foam application; and

.3 apply foam for $300 \pm 2 \text{ s}$. Stop foam application and after a further $300 \pm 10 \text{ s}$ place the burnback pot, containing $2 \pm 0.1 \text{ l}$ of fuel in the centre of the tray and ignite. Visually estimate when 25% of the tray is covered by sustained flames or by "flare up" flames (see Note below), ignoring any faint, barely visible, or transient flames.

Note: During the burnback test, a "flare up" may occur, in which large flames may be sustained for periods typically from 30 s to 3 min before decreasing in intensity.

3.9.7 Permissible limits:

- .1 extinction time: not more than 5 min; and
- .2 burnback time: not less than 15 min for 25% of the surface.

3.10 Corrosiveness

The storage container should be compatible with its foam concentrate throughout the service life of the foam such that the chemical and physical properties of the foam should not deteriorate below the initial values accepted by the Administration.

3.11 Volumic mass

According to standard ASTM D 1298-85.

| | |
|--------------|---|
| Title | MSC Circulars / MSC.1/Circ.1312 |
| Note | Supersedes MSC/Circ.582, MSC/Circ.582/Corr.1 and MSC/Circ.799 |

3.12 Batch certificate

The foam concentrate should be delivered with a declaration of the main characteristics (sedimentation, pH value, expansion ratio, drainage time and volumetric mass). The declaration should be issued by the maker and will be the basis for the annual condition test.

3.13 Foam concentrate container marking

Each foam concentrate container should be marked with complete information needed to identify the liquid and confirm its intended use. As a minimum, the following information should be included:

- .1 name and address of manufacturer;
- .2 product designation;
- .3 type of foam (synthetic, protein-based, etc.);
- .4 intended use (regular or alcohol-resistant);
- .5 batch number and reference to batch certificate;
- .6 date of manufacture;
- .7 expiry date;
- .8 reference to test standard and approvals;
- .9 recommended usage concentration;
- .10 indication if seawater compatible;
- .11 maximum and minimum storage temperature;
- .12 required onboard storage tank materials (steel, stainless steel, FRP, etc.);
- .13 quantity of foam concentrate;
- .14 indication of film forming capability; and
- .15 safety, health and environmental information.

3.14 Reference test and annual periodic re-test for protein-based alcohol-resistant foam concentrates

Protein-based alcohol-resistant foam concentrates should be required to demonstrate manufacturing consistency through an annual small-scale test at a recognized test laboratory. The reference test should be performed at the same time and at the same recognized laboratory as the full-scale test defined in subsection 3.9.

The concentrate should be tested according to standards ISO 7203-3 Annex C, EN 1568-4 Annex I, SP Method 2580 or another standard acceptable to the Administration. The reference test and annual test should be carried out to the same standard.

The concentrate is deemed to fail the test if the results from the annual small scale test indicate significant changes in the foam quality compared to the reference test.

4 PERIODICAL CONTROLS OF FOAM CONCENTRATES STORED ON BOARD

The attention of the Administration is drawn to the fact that particular installation conditions (excessive ambient storage temperature, contamination of the foam concentrate, incomplete filling of the tank, etc.) may lead to an abnormal ageing of the concentrates.

For periodical control of foam concentrates, the tests under paragraphs 4.1 to 4.7 should be performed by the shipowner or operator. They should be carried out at laboratories or authorized service suppliers acceptable to the Administration.

The deviations in the values obtained by these tests, in respect of those obtained during the type approval tests,

Disclaimer : Although all possible efforts have been made to ensure correctness and completeness of the information contained in this Web Service, the Korean Register of Shipping is not responsible for any errors or omissions made herein, nor held for any actions taken by any party as a result of information retrieved from this Web Service.

E-mail : krcon@krs.co.kr

| | |
|--------------|---|
| Title | MSC Circulars / MSC.1/Circ.1312 |
| Note | Supersedes MSC/Circ.582, MSC/Circ.582/Corr.1 and MSC/Circ.799 |

should be within the ranges acceptable to the Administration.

Tests under paragraphs 4.1, 4.3 and 4.4 should be carried out on samples maintained at 60°C for 24 h and subsequently cooled to the test temperature.

4.1 Sedimentation

According to paragraph 3.3 above.

4.2 pH value

According to paragraph 3.5 above.

4.3 Expansion ratio

According to paragraph 3.7 above.

4.4 Drainage time

According to paragraph 3.8 above.

4.5 Volumic mass

According to paragraph 3.11 above.

4.6 Small scale fire test for protein-based alcohol-resistant foam concentrates

According to paragraph 3.14 above.

4.7 Chemical stability test for protein-based alcohol-resistant foam concentrates

Protein-based alcohol-resistant foam concentrates should be subjected to a stability test with acetone. A foam solution should be prepared at the approved concentration and gently applied to the surface of a tray containing acetone. The concentrate is deemed to fail the test if the foam solution mixes with the acetone.

5 INTERVALS OF PERIODIC CONTROLS

Except for tests in accordance with paragraph 4.7 the first periodical control of foam concentrates should be performed not more than 3 years after being supplied to the ship, and after that, every year. The tests required by paragraph 4.7 should be performed prior to delivery to the ship and annually thereafter.

| | |
|-------|---|
| Title | MSC Circulars / MSC.1/Circ.1312 |
| Note | Supersedes MSC/Circ.582, MSC/Circ.582/Corr.1 and MSC/Circ.799 |

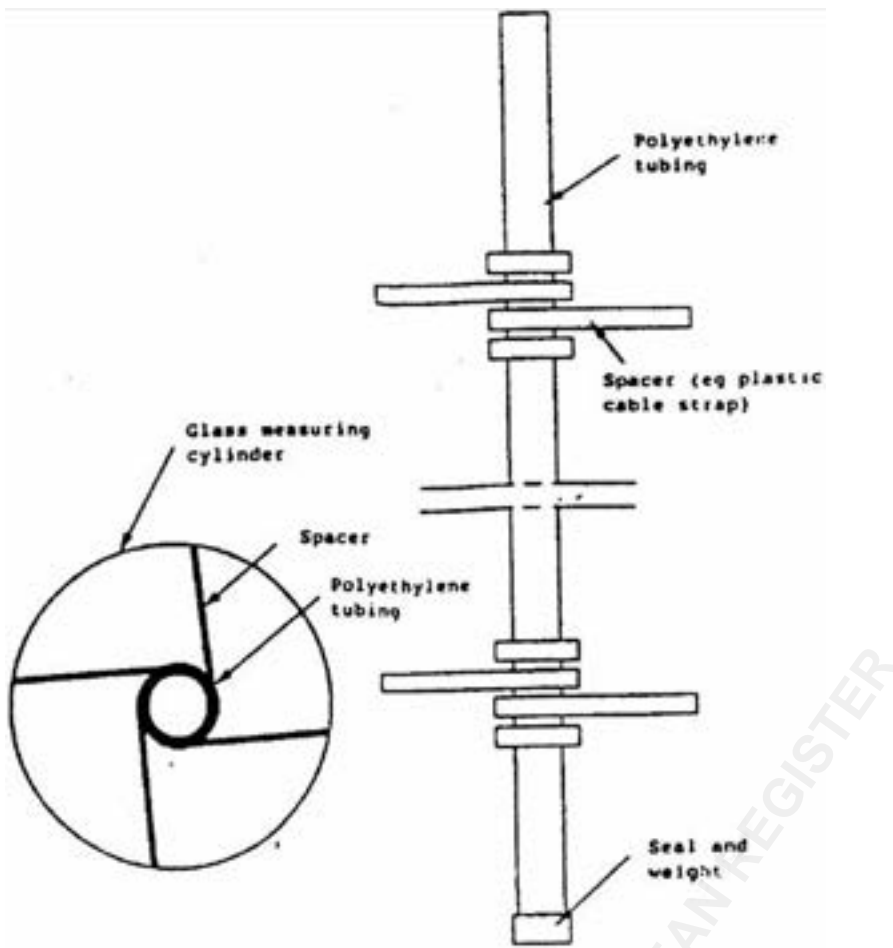

Figure 1 - Typical form of polyethylene tube

| | |
|-------|---|
| Title | MSC Circulars / MSC.1/Circ.1312 |
| Note | Supersedes MSC/Circ.582, MSC/Circ.582/Corr.1 and MSC/Circ.799 |

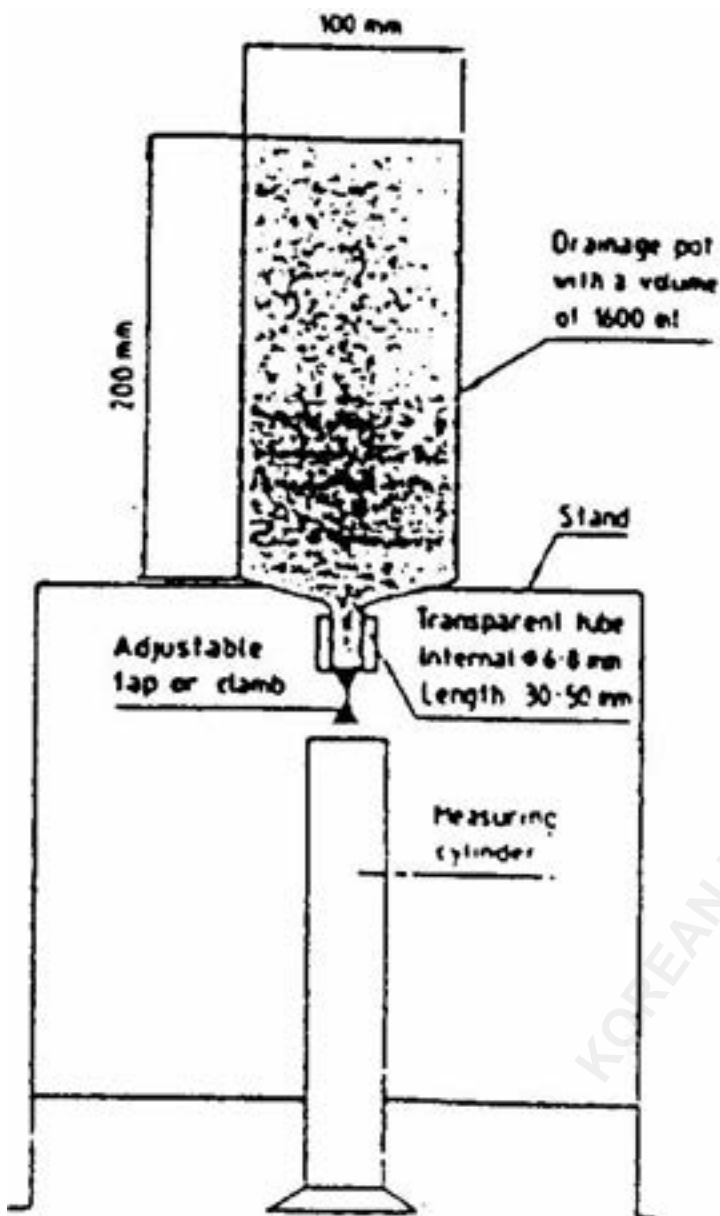

Figure 2 - Collecting vessel for determination of expansion and drainage time

| | |
|-------|---|
| Title | MSC Circulars / MSC.1/Circ.1312 |
| Note | Supersedes MSC/Circ.582, MSC/Circ.582/Corr.1 and MSC/Circ.799 |

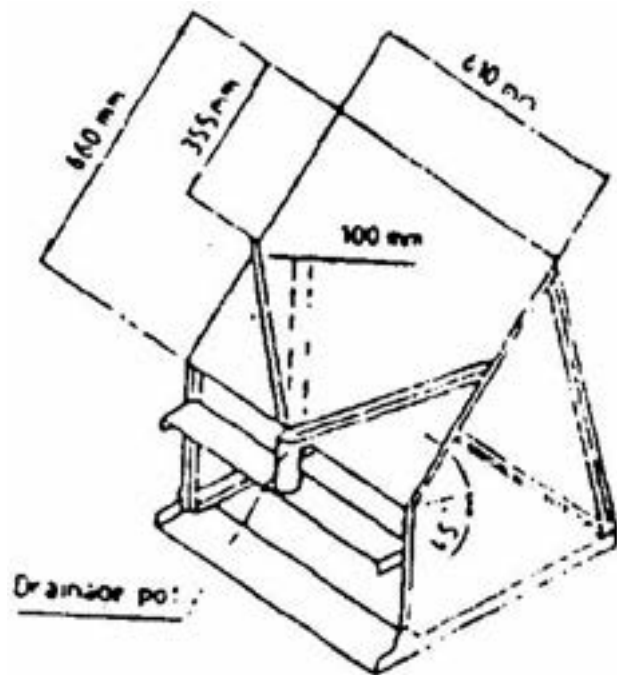

Figure 3 - Foam collector for expansion and drainage measurement

Note: Suitable materials for the collection surface are stainless steel, aluminium, brass or plastics

KOREAN REGISTER

| | |
|-------|---|
| Title | MSC Circulars / MSC.1/Circ.1312 |
| Note | Supersedes MSC/Circ.582, MSC/Circ.582/Corr.1 and MSC/Circ.799 |

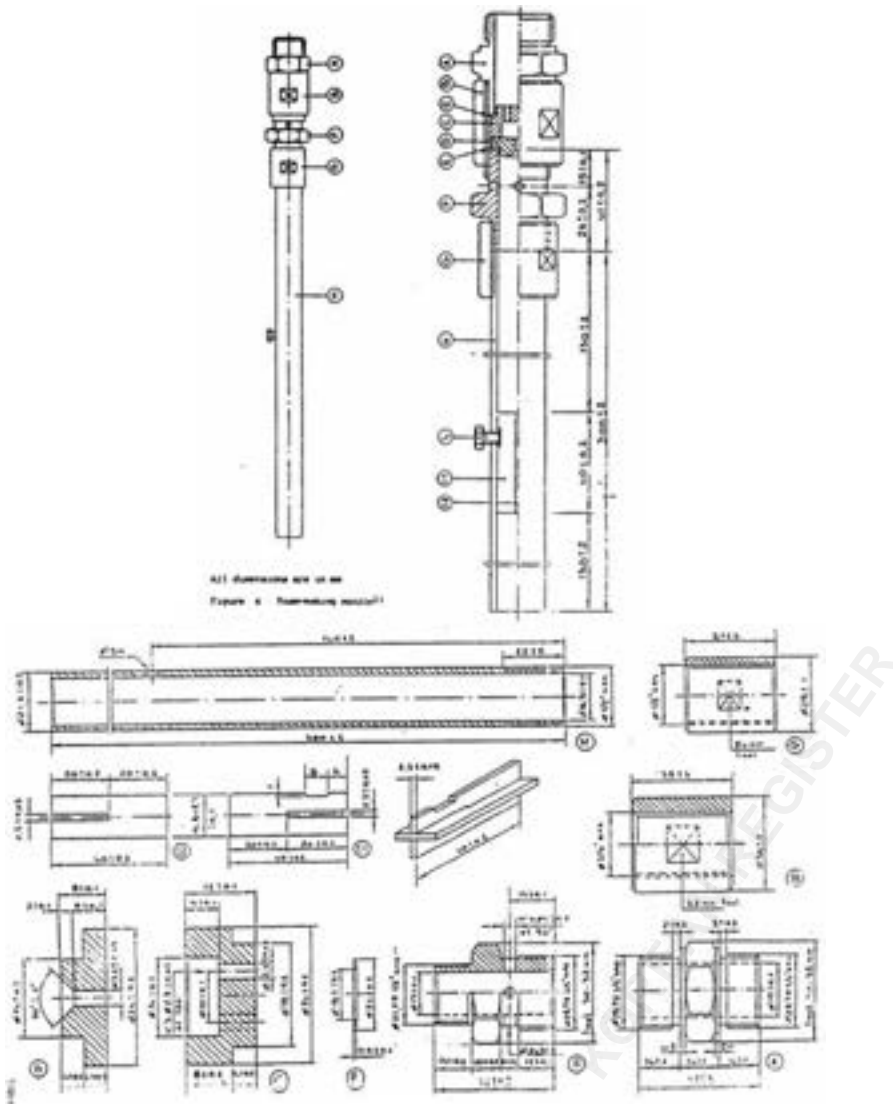

Figure 4 - Foam making nozzle

MSC.1/Circ.1312/Corr.1

22 November 2011

REVISED GUIDELINES FOR THE PERFORMANCE AND TESTING CRITERIA, AND SURVEYS OF FOAM CONCENTRATES FOR FIXED FIRE- EXTINGUISHING SYSTEMS

Corrigendum

In the annex to the circular, replace figures 1 to 4 with the following:

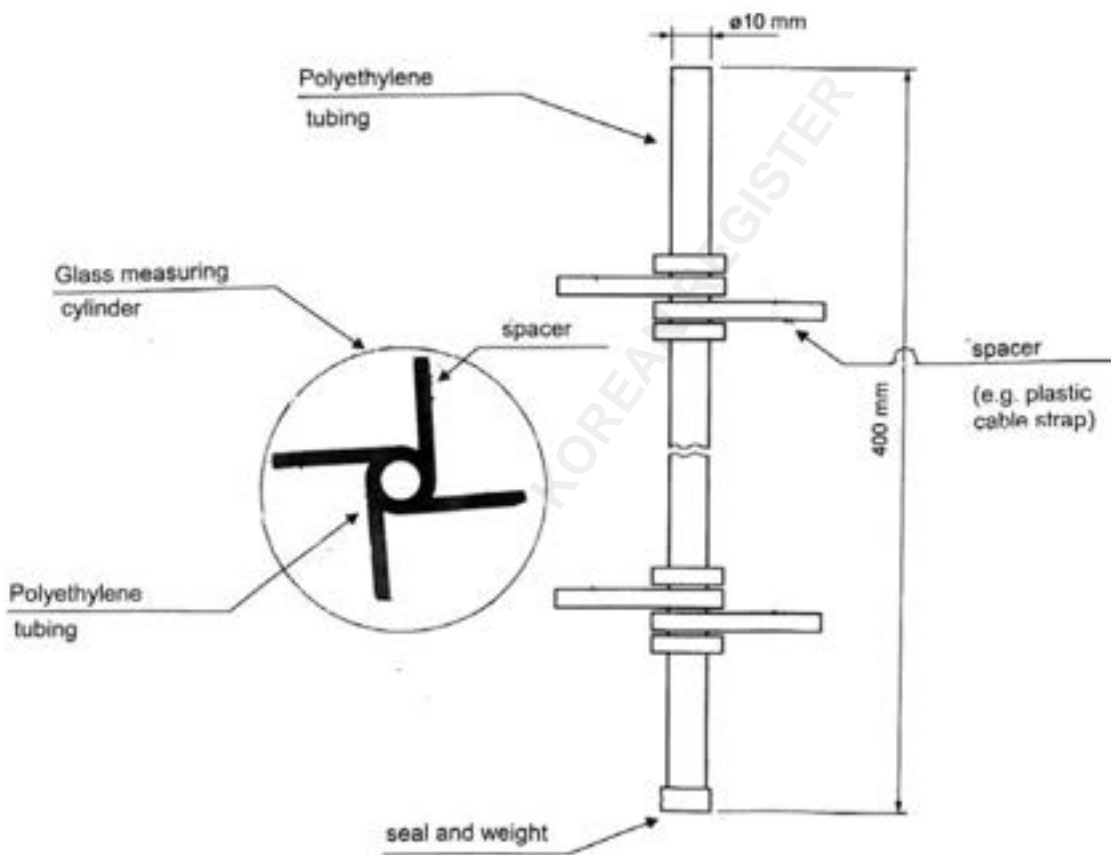

Figure 1 - Typical form of polyethylene tube

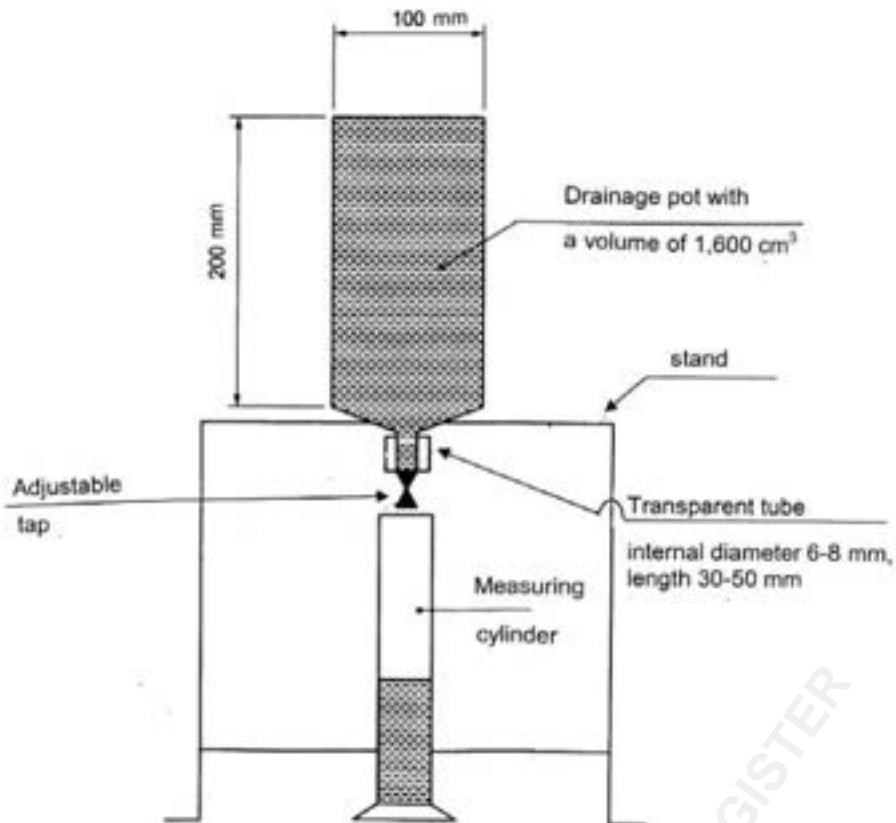

Figure 2 - Collecting vessel for determination of expansion and drainage time

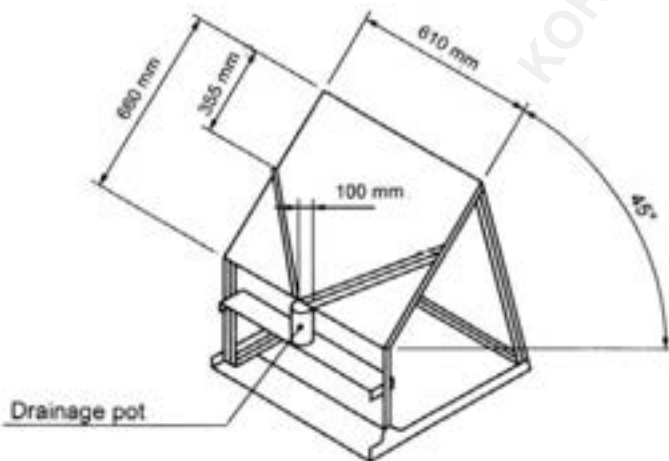
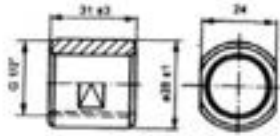

Figure 3 - Foam collector for expansion and drainage measurement

Note: Suitable materials for the collection surface are stainless steel, aluminium, brass or plastics

G



H

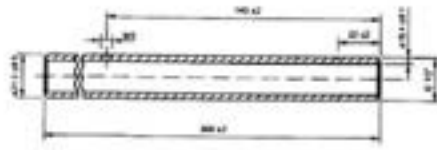

I

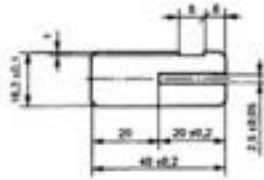

K

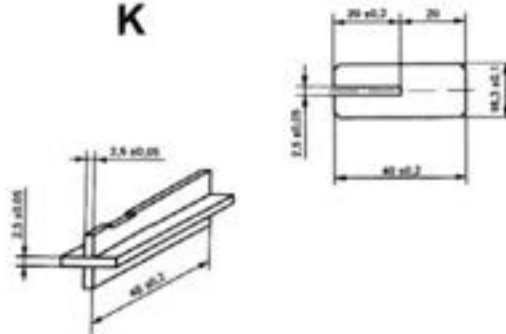

KOREAN REGISTER

4 ALBERT EMBANKMENT
LONDON SE1 7SR
Telephone: +44 (0)20 7735 7611 Fax: +44 (0)20 7587 3210

MSC.1/Circ.1318/Rev.1
25 May 2021

**REVISED GUIDELINES FOR THE MAINTENANCE AND INSPECTIONS OF
FIXED CARBON DIOXIDE FIRE-EXTINGUISHING SYSTEMS**

- 1 The Maritime Safety Committee, at its eighty-sixth session (27 May to 5 June 2009), having considered the proposal by the Sub-Committee on Fire Protection, at its fifty-third session, approved *Guidelines for the maintenance and inspections of fixed carbon dioxide fire-extinguishing systems* (MSC.1/Circ.1318).
- 2 In order to address the need to clarify the hydrostatic testing regime for high-pressure CO₂ cylinders and to align the relevant requirements in the Guidelines with those in the *Revised guidelines for the maintenance and inspection of fire protection systems and appliances* (MSC.1/Circ.1432), the Committee, at its 103rd session (5 to 14 May 2021), approved amendments to the above-mentioned Guidelines, prepared by the Sub-Committee on Ship Systems and Equipment, at its seventh session, with a view to dissemination as MSC.1/Circ.1318/Rev.1. The text of the *Revised guidelines for the maintenance and inspections of fixed carbon dioxide fire-extinguishing systems* is set out in the annex.
- 3 Member Governments are invited to apply the annexed Revised guidelines when inspecting fixed carbon dioxide fire-extinguishing systems on board all ships and bring them to the attention of ship designers, shipowners, equipment manufacturers, and other parties concerned.
- 4 This circular supersedes MSC.1/Circ.1318.

ANNEX

REVISED GUIDELINES FOR THE MAINTENANCE AND INSPECTIONS OF FIXED CARBON DIOXIDE FIRE-EXTINGUISHING SYSTEMS

1 General

These Revised guidelines provide the minimum recommended level of maintenance and inspections for fixed carbon dioxide fire-extinguishing systems on all ships and are intended to demonstrate that the system is kept in good working order as specified in SOLAS regulation II-2/14.2.1.2. These Revised guidelines are intended to supplement the fire-extinguishing system manufacturer's approved maintenance instructions. Certain maintenance procedures and inspections may be performed by competent crewmembers, while others should be performed by persons specially trained in the maintenance of such systems. The onboard maintenance plan should indicate which parts of the recommended inspections and maintenance should be completed by trained personnel.

2 Safety

Whenever carbon dioxide fire-extinguishing systems are subjected to inspection or maintenance, strict safety precautions should be followed to prevent the possibility that individuals performing or witnessing the activities are placed at risk. Prior to performing any work, a safety plan should be developed to account for all personnel and establish an effective communications system between the inspection personnel and the on-duty crew. Measures to avoid accidental discharges such as locking or removing the operating arms from directional valves, or shutting and locking the system block valve should be taken as the initial procedure for the protection of personnel performing any maintenance or inspections. All personnel should be notified of the impending activities before work is begun.

3 Maintenance and inspection plan

Fixed carbon dioxide fire-extinguishing systems should be kept in good working order and readily available for immediate use. Maintenance and inspections should be carried out in accordance with the ship's maintenance plan having due regard to ensuring the reliability of the system. The onboard maintenance plan should be included in the ship's safety management system and should be based on the system manufacturer's recommendations including:

- .1 maintenance and inspection procedures and instructions;
- .2 required schedules for periodic maintenance and inspections;
- .3 listing of recommended spare parts; and
- .4 records of inspections and maintenance, including corrective actions taken to maintain the system in operable condition.

4 Monthly inspections

4.1 At least every 30 days a general visual inspection should be made of the overall system condition for obvious signs of damage, and should include verification that:

- .1 all stop valves are in the closed position;
- .2 all releasing controls are in the proper position and readily accessible for immediate use;
- .3 all discharge piping and pneumatic tubing is intact and has not been damaged;
- .4 all high-pressure cylinders are in place and properly secured; and
- .5 the alarm devices are in place and do not appear damaged.

4.2 In addition, on low pressure systems the inspections should verify that:

- .1 the pressure gauge is reading in the normal range;
- .2 the liquid level indicator is reading within the proper level;
- .3 the manually operated storage tank main service valve is secured in the open position; and
- .4 the vapour supply line valve is secured in the open position.

5 Annual inspections

The following minimum level of maintenance and inspections should be carried out in accordance with the system manufacturer's instructions and safety precautions:

- .1 the boundaries of the protected space should be visually inspected to confirm that no modifications have been made to the enclosure that have created uncloseable openings that would render the system ineffective;
- .2 all storage containers should be visually inspected for any signs of damage, rust or loose mounting hardware. Cylinders that are leaking, corroded, dented or bulging should be hydrostatically retested or replaced;
- .3 system piping should be visually inspected to check for damage, loose supports and corrosion. Nozzles should be inspected to ensure they have not been obstructed by the storage of spare parts or a new installation of structure or machinery;
- .4 the manifold should be inspected to verify that all flexible discharge hoses and fittings are properly tightened; and
- .5 all entrance doors to the protected space should close properly and should have warning signs, which indicate that the space is protected by a fixed carbon dioxide system and that personnel should evacuate immediately if the alarms sound. All remote releasing controls should be checked for clear operating instructions and indication as to the space served.

6 Minimum recommended maintenance

6.1 At least biennially (intervals of 2 years \pm 3 months) in passenger ships or at each intermediate, periodical or renewal survey¹ in cargo ships, the following maintenance should be carried out (to assist in carrying out the recommended maintenance, examples of service charts are set out in the appendix):

- .1 all high-pressure cylinders and pilot cylinders should be weighed or have their contents verified by other reliable means to confirm that the available charge in each is above 90% of the nominal charge. Cylinders containing less than 90% of the nominal charge should be refilled. The liquid level of low pressure storage tanks should be checked to verify that the required amount of carbon dioxide to protect the largest hazard is available;
- .2 the hydrostatic test date of all storage containers should be checked. High-pressure cylinders should be subjected to periodical tests at intervals not exceeding 10 years. At the 10-year inspection, at least 10% of the total number provided should be subjected to an internal inspection and hydrostatic test². If one or more cylinders fail, a total of 50% of the onboard cylinders should be tested. If further cylinders fail, all cylinders should be tested. Before the 20-year anniversary and every 10-year anniversary thereafter, all cylinders should be subjected to a hydrostatic test. Flexible hoses should be replaced at the intervals recommended by the manufacturer and not exceeding every 10 years. When cylinders are removed for testing, the cylinders should be replaced such that the quantity of fire-extinguishing medium continues to satisfy the requirements of 2.2.1 of chapter 5 of the FSS Code, subject to SOLAS regulation II-2/14.2; and
- .3 the discharge piping and nozzles should be tested to verify that they are not blocked. The test should be performed by isolating the discharge piping from the system and flowing dry air or nitrogen from test cylinders or suitable means through the piping.

6.2 At least biennially (intervals of 2 years \pm 3 months) in passenger ships or at each renewal survey¹ in cargo ships, the following maintenance should be carried out by service technicians/ specialists trained to standards accepted by the Administration:

- .1 where possible, all activating heads should be removed from the cylinder valves and tested for correct functioning by applying full working pressure through the pilot lines.

In cases where this is not possible, pilot lines should be disconnected from the cylinder valves and blanked off or connected together and tested with full working pressure from the release station and checked for leakage.

In both cases this should be carried out from one or more release stations when installed. If manual pull cables operate the remote release controls, they should be checked to verify the cables and corner pulleys are in good condition and freely move and do not require an excessive amount of travel to activate the system;

¹ Refer to the *Survey Guidelines under the Harmonized System of Survey and Certification (HSSC)*, 2019 (resolution A.1140(31)).

² Refer to standard ISO 18119:2018 – Gas cylinders – Seamless steel and seamless aluminium-alloy gas cylinders and tubes – Periodic inspection and testing.

- .2 all cable components should be cleaned and adjusted as necessary, and the cable connectors should be properly tightened. If the remote release controls are operated by pneumatic pressure, the tubing should be checked for leakage, and the proper charge of the remote releasing station pilot gas cylinders should be verified. All controls and warning devices should function normally, and the time delay, if fitted should prevent the discharge of gas for the required time period; and
- .3 after completion of the work, the system should be returned to service. All releasing controls should be verified in the proper position and connected to the correct control valves. All pressure switch interlocks should be reset and returned to service. All stop valves should be in the closed position.

7 Five-year service

At least once every five years, internal inspection of all control valves should be performed.

APPENDIX

EXAMPLE SERVICE CHARTS

HIGH PRESSURE CO₂ SYSTEM

| | | | |
|-------|--------------------|----------|--|
| Date: | Name of ship/unit: | IMO No.: | |
|-------|--------------------|----------|--|

Technical description

| No. | Text | Value |
|-----|------------------------------------|-------|
| 1 | Manufacturer | |
| 2 | Number of main cylinders | |
| 3 | Main cylinders capacity (each) | |
| 4 | Number of pilot cylinders | |
| 5 | Pilot cylinder capacity (each) | |
| 6 | Number of distribution lines | |
| 7 | Oldest cylinder pressure test date | |
| 8 | Protected space(s) | |
| 9 | Date flexible hoses fitted/renewed | |

Description of inspection/Tests

| No. | Description | Carried out | Not carried out | Not applicable | Comment |
|-----|--|-------------|-----------------|----------------|---------|
| 1 | Release controls and distribution valves secured to prevent accidental discharge | | | | |
| 2 | Contents in main cylinders checked by weighing | | | | |
| 3 | Contents in main cylinders checked by liquid level indicator | | | | |
| 4 | Contents of pilot cylinders checked | | | | |
| 5 | All cylinder valves visually inspected | | | | |
| 6 | All cylinder clamps and connections checked for tightness | | | | |
| 7 | Manifold visually inspected | | | | |
| 8 | Manifold tested for leakage, by applying dry working air | | | | |
| 9 | Main valve and distribution valves visually inspected | | | | |
| 10 | Main valve and distribution valves tested for operation | | | | |
| 11 | Time delay devices tested for correct setting* | | | | |
| 12 | Remote release system visually inspected | | | | |
| 13 | Remote release system tested | | | | |
| 14 | Servo tubing/pilot lines pressure tested at maximum working pressure and checked for leakages and blockage | | | | |
| 15 | Manual pull cables, pulleys, gang releases tested, serviced and tightened/adjusted as necessary | | | | |
| 16 | Release stations visually inspected | | | | |

| No. | Description | Carried out | Not carried out | Not applicable | Comment |
|-----|--|-------------|-----------------|----------------|---------|
| 17 | Warning alarms (audible/visual) tested | | | | |
| 18 | Fan stop tested* | | | | |
| 19 | 10% of cylinders and pilot cylinder/s pressure tested every 10 years. All cylinders and pilot cylinder/s pressure tested before the 20-year anniversary and every 10-year anniversary thereafter | | | | |
| 20 | Internal inspection of all control valves performed at least once every five years | | | | |
| 21 | Distribution lines and nozzles blown through, by applying dry working air | | | | |
| 22 | All doors, hinges and locks inspected* | | | | |
| 23 | All instruction and warning signs on installation inspected | | | | |
| 24 | All flexible hoses renewed and check valves in manifold visually inspected every 10 years | | | | |
| 25 | Release controls and distribution valves reconnected and system put back in service | | | | |
| 26 | Inspection date tags attached | | | | |

* If fitted as part of the CO₂ system.

LOW PRESSURE CO₂ SYSTEM

| | | | |
|-------|--------------------|----------|--|
| Date: | Name of ship/unit: | IMO No.: | |
|-------|--------------------|----------|--|

Technical description

| No. | Text | Value |
|-----|--------------------------------|-------|
| 1 | Manufacturer | |
| 2 | No. of tanks | |
| 3 | Tanks capacity (tonnes) | |
| 4 | Number of pilot cylinders | |
| 5 | Pilot cylinder capacity (each) | |
| 6 | Number of distribution lines | |
| 7 | Protected space(s) | |

Description of inspection/Tests

| No. | Description | Carried out | Not carried out | Not applicable | Comment |
|-----|--|-------------|-----------------|----------------|---------|
| 1 | Tank main service valve closed and secured to prevent accidental discharge | | | | |
| 2 | Distribution valves verified closed | | | | |
| 3 | Check correct function of level indicator | | | | |
| 4 | Contents of CO ₂ tank checked by tank level indicator | | | | |

| No. | Description | Carried out | Not carried out | Not applicable | Comment |
|-----|--|-------------|-----------------|----------------|---------|
| 5 | Contents of CO ₂ tank checked by riser tube reading | | | | |
| 6 | Contents of CO ₂ tank checked by level control valve | | | | |
| 7 | Supports of tank inspected | | | | |
| 8 | Insulation on tank inspected | | | | |
| 9 | Safety valves of tank inspected | | | | |
| 10 | Safety valves of tank tested | | | | |
| 11 | Contents of pilot cylinders checked | | | | |
| 12 | Start/stop function of cooling compressors tested | | | | |
| 13 | All connected electrical alarms and indicators tested | | | | |
| 14 | Main manifold valve inspected | | | | |
| 15 | Internal inspection of all control valves performed at least once every five years | | | | |
| 16 | Main manifold valve tested | | | | |
| 17 | Distribution valves inspected | | | | |
| 18 | Distribution valves tested | | | | |
| 19 | Release stations inspected | | | | |
| 20 | Total flooding release mechanism inspected | | | | |
| 21 | Total flooding release mechanism tested | | | | |
| 22 | Time delay devices tested for correct setting* | | | | |
| 23 | Warning alarms tested | | | | |
| 24 | Fan stop tested* | | | | |
| 25 | Distribution lines and nozzles inspected | | | | |
| 26 | Distribution lines and nozzles tested | | | | |
| 27 | Distribution lines and nozzles blown through | | | | |
| 28 | All doors, hinges and locks inspected* | | | | |
| 29 | All instruction plates inspected | | | | |
| 30 | Tank main service valve reopened and secured open | | | | |
| 31 | System put back in service | | | | |
| 32 | Inspection date tags attached | | | | |

* If fitted as part of the CO₂ system.

| | |
|--------------|--|
| Title | MSC Circulars / MSC.1/Circ.1432 |
| Note | This circular supersedes MSC/Circ.850. |

MSC.1/Circ.1432

31 May 2012

REVISED GUIDELINES FOR THE MAINTENANCE AND INSPECTION OF FIRE PROTECTION SYSTEMS AND APPLIANCES

1 The Maritime Safety Committee, at its ninetieth session (16 to 25 May 2012), having considered a proposal by the Sub-Committee on Fire Protection, at its fifty-fifth session, and recognizing the need to include maintenance and inspection guidelines for the latest advancements in fire-protection systems and appliances, approved the Revised Guidelines for the maintenance and inspection of fire protection systems and appliances, as set out in the annex.

2 Member Governments are invited to apply the annexed Guidelines when performing maintenance, testing and inspections in accordance with SOLAS regulation II-2/14.2.2.1 on or after 31 May 2013 and bring the annexed Guidelines to the attention of shipowners, shipmasters, ships' officers and crew and all other parties concerned.

3 This circular supersedes MSC/Circ.850.

ANNEX

REVISED GUIDELINES FOR THE MAINTENANCE AND INSPECTION OF FIRE PROTECTION SYSTEMS AND APPLIANCES

1 Application

These Guidelines apply to all ships and provide the minimum recommended level of maintenance and inspections for fire protection systems and appliances. This information may be used as a basis for the ship's onboard maintenance plan required by SOLAS regulation II-2/14. These Guidelines do not address maintenance and inspection of fixed carbon dioxide systems or portable fire extinguishers. Refer to the comprehensive instructions provided in the Guidelines for the maintenance and inspections of fixed carbon dioxide fire-extinguishing systems (MSC.1/Circ.1318) for fixed carbon dioxide systems, and in the Improved Guidelines for marine portable fire extinguishers (resolution A.951(23)) for portable fire extinguishers.

2 Operational readiness

All fire protection systems and appliances should at all times be in good order and readily available for immediate use while the ship is in service. If a fire protection system is undergoing maintenance, testing or repair, then suitable arrangements should be made to ensure safety is not diminished through the provision of alternate fixed or portable fire protection equipment or other measures. The onboard maintenance plan should include provisions for this purpose.

3 Maintenance and testing

3.1 Onboard maintenance and inspections should be carried out in accordance with the ship's maintenance plan, which should include the minimum elements listed in sections 4 to 10 of these Guidelines.

3.2 Certain maintenance procedures and inspections may be performed by competent crew members who have completed an advanced fire-fighting training course, while others should be performed by persons specially trained in the maintenance of such systems. The onboard maintenance plan should indicate which parts of the recommended inspections and maintenance are to be completed by trained personnel.

Disclaimer : Although all possible efforts have been made to ensure correctness and completeness of the information contained in this Web Service, the Korean Register of Shipping is not responsible for any errors or omissions made herein, nor held for any actions taken by any party as a result of information retrieved from this Web Service.

E-mail : krcos@krs.co.kr



| | |
|--------------|--|
| Title | MSC Circulars / MSC.1/Circ.1432 |
| Note | This circular supersedes MSC/Circ.850. |

recommended inspections and maintenance are to be completed by trained personnel.

3.3 Inspections should be carried out by the crew to ensure that the indicated weekly, monthly, quarterly, annual, two-year, five-year and ten-year actions are taken for the specified equipment, if provided. Records of the inspections should be carried on board the ship, or may be computer-based. In cases where the inspections and maintenance are carried out by trained service technicians other than the ship's crew, inspection reports should be provided at the completion of the testing.

3.4 In addition to the onboard maintenance and inspections stated in these Guidelines, manufacturer's maintenance and inspection guidelines should be followed.

3.5 Where particular arrangements create practical difficulties, alternative testing and maintenance procedures should be to the satisfaction of the Administration.

4 Weekly testing and inspections

4.1 Fixed fire detection and alarm systems Verify all fire detection and fire alarm control panel indicators are functional by operating the lamp/indicator test switch.

4.2 Fixed gas fire-extinguishing systems

- .1 verify all fixed fire-extinguishing system control panel indicators are functional by operating the lamp/indicator test switch; and
- .2 verify all control/section valves are in the correct position.

4.3 Fire doors

Verify all fire door control panel indicators, if provided, are functional by operating the lamp/indicator switch.

4.4 Public address and general alarm systems

Verify all public address systems and general alarm systems are functioning properly.

4.5 Breathing apparatus

Examine all breathing apparatus and EEBD cylinder gauges to confirm they are in the correct pressure range.

4.6 Low-location lighting

Verify low-location lighting systems are functional by switching off normal lighting in selected locations.

4.7 Water mist, water spray and sprinkler systems

- .1 verify all control panel indicators and alarms are functional;
- .2 visually inspect pump unit and its fittings; and
- .3 check the pump unit valve positions, if valves are not locked, as applicable.

5 Monthly testing and inspections

Monthly inspections should be carried out to ensure that the indicated actions are taken for the specified equipment.

5.1 Fire mains, fire pumps, hydrants, hoses and nozzles

- .1 verify all fire hydrants, hose and nozzles are in place, properly arranged, and are in serviceable condition;
- .2 operate all fire pumps to confirm that they continue to supply adequate pressure; and
- .3 emergency fire pump fuel supply adequate, and heating system in satisfactory condition, if applicable.

5.2 Fixed gas fire-extinguishing systems

Verify containers/cylinders fitted with pressure gauges are in the proper range and the installation free from leakage.

5.3 Foam fire-extinguishing systems

Disclaimer : Although all possible efforts have been made to ensure correctness and completeness of the information contained in this Web Service, the Korean Register of Shipping is not responsible for any errors or omissions made herein, nor held for any actions taken by any party as a result of information retrieved from this Web Service.

E-mail : krcos@krs.co.kr

| | |
|--------------|--|
| Title | MSC Circulars / MSC.1/Circ.1432 |
| Note | This circular supersedes MSC/Circ.850. |

5.3 Fixed fire-extinguishing systems

Verify all control and section valves are in the proper open or closed position, and all pressure gauges are in the proper range.

5.4 Water mist, water spray and sprinkler systems

- 1 verify all control, pump unit and section valves are in the proper open or closed position;
- 2 verify sprinkler pressure tanks or other means have correct levels of water;
- 3 test automatic starting arrangements on all system pumps so designed;
- 4 verify all standby pressure and air/gas pressure gauges are within the proper pressure ranges; and
- 5 test a selected sample of system section valves for flow and proper initiation of alarms.

(Note – The valves selected for testing should be chosen to ensure that all valves are tested within a one-year period.)

5.5 Firefighter's outfits

Verify lockers providing storage for fire-fighting equipment contain their full inventory and equipment is in serviceable condition.

5.6 Fixed dry chemical powder systems

Verify all control and section valves are in the proper open or closed position, and all pressure gauges are in the proper range.

5.7 Fixed aerosol extinguishing systems

- 1 verify all electrical connections and/or manual operating stations are properly arranged, and are in proper condition; and
- 2 verify the actuation system/control panel circuits are within manufacturer's specifications.

5.8 Portable foam applicators

Verify all portable foam applicators are in place, properly arranged, and are in proper condition.

5.9 Wheeled (mobile) fire extinguishers

Verify all extinguishers are in place, properly arranged, and are in proper condition.

5.10 Fixed fire detection and alarm systems

Test a sample of detectors and manual call points so that all devices have been tested within five years. For very large systems the sample size should be determined by the Administration.

6 Quarterly testing and inspections

Quarterly inspections should be carried out to ensure that the indicated actions are taken for the specified equipment:

6.1 Fire mains, fire pumps, hydrants, hoses and nozzles

Verify international shore connection(s) is in serviceable condition.

6.2 Foam fire-extinguishing systems

Verify the proper quantity of foam concentrate is provided in the foam system storage tank.

6.3 Ventilation systems and fire dampers

Test all fire dampers for local operation.

6.4 Fire doors

Test all fire doors located in main vertical zone bulkheads for local operation.

Disclaimer : Although all possible efforts have been made to ensure correctness and completeness of the information contained in this Web Service, the Korean Register of Shipping is not responsible for any errors or omissions made herein, nor held for any actions taken by any party as a result of information retrieved from this Web Service.

E-mail : krcos@krs.co.kr

| | |
|--------------|--|
| Title | MSC Circulars / MSC.1/Circ.1432 |
| Note | This circular supersedes MSC/Circ.850. |

7 Annual testing and inspections

Annual inspections should be carried out to ensure that the indicated actions are taken for the specified equipment:

7.1 Fire mains, fire pumps, hydrants, hoses and nozzles

- .1 visually inspect all accessible components for proper condition;
- .2 flow test all fire pumps for proper pressure and capacity. Test emergency fire pump with isolation valves closed;
- .3 test all hydrant valves for proper operation;
- .4 pressure test a sample of fire hoses at the maximum fire main pressure, so that all fire hoses are tested within five years;
- .5 verify all fire pump relief valves, if provided, are properly set;
- .6 examine all filters/strainers to verify they are free of debris and contamination; and
- .7 nozzle size/type correct, maintained and working.

7.2 Fixed fire detection and fire alarm systems

- .1 test all fire detection systems and fire detection systems used to automatically release fire-extinguishing systems for proper operation, as appropriate;
- .2 visually inspect all accessible detectors for evidence of tampering obstruction, etc., so that all detectors are inspected within one year; and
- .3 test emergency power supply switchover.

7.3 Fixed gas fire-extinguishing systems

- .1 visually inspect all accessible components for proper condition;
- .2 externally examine all high pressure cylinders for evidence of damage or corrosion;
- .3 check the hydrostatic test date of all storage containers;
- .4 functionally test all fixed system audible and visual alarms;
- .5 verify all control/section valves are in the correct position;
- .6 check the connections of all pilot release piping and tubing for tightness;
- .7 examine all flexible hoses in accordance with manufacturer's recommendations;
- .8 test all fuel shut-off controls connected to fire-protection systems for proper operation;
- .9 the boundaries of the protected space should be visually inspected to confirm that no modifications have been made to the enclosure that have created uncloseable openings that would render the system ineffective; and
- .10 if cylinders are installed inside the protected space, verify the integrity of the double release lines inside the protected space, and check low pressure or circuit integrity monitors on release cabinet, as applicable.

7.4 Foam fire-extinguishing systems

- .1 visually inspect all accessible components for proper condition;
- .2 functionally test all fixed system audible alarms;
- .3 flow test all water supply and foam pumps for proper pressure and capacity, and confirm flow at the required pressure in each section (Ensure all piping is thoroughly flushed with fresh water after service.);
- .4 test all system cross connections to other sources of water supply for proper operation;

Disclaimer : Although all possible efforts have been made to ensure correctness and completeness of the information contained in this Web Service, the Korean Register of Shipping is not responsible for any errors or omissions made herein, nor held for any actions taken by any party as a result of information retrieved from this Web Service.



E-mail : krcos@krs.co.kr

| | |
|--------------|--|
| Title | MSC Circulars / MSC.1/Circ.1432 |
| Note | This circular supersedes MSC/Circ.850. |

- .5 verify all pump relief valves, if provided, are properly set;
- .6 examine all filters/strainers to verify they are free of debris and contamination;
- .7 verify all control/section valves are in the correct position;
- .8 blow dry compressed air or nitrogen through the discharge piping or otherwise confirm the pipework and nozzles of high expansion foam systems are clear of any obstructions, debris and contamination. This may require the removal of nozzles, if applicable;
- .9 take samples from all foam concentrates carried on board and subject them to the periodical control tests in MSC.1/Circ.1312, for low expansion foam, or MSC/Circ.670 for high expansion foam.
(Note: Except for non-alcohol resistant foam, the first test need not be conducted until 3 years after being supplied to the ship.); and
- .10 test all fuel shut-off controls connected to fire-protection systems for proper operation.

7.5 Water mist, water spray and sprinkler systems

- .1 verify proper operation of all water mist, water-spray and sprinkler systems using the test valves for each section;
- .2 visually inspect all accessible components for proper condition;
- .3 externally examine all high pressure cylinders for evidence of damage or corrosion;
- .4 check the hydrostatic test date of all high pressure cylinders;
- .5 functionally test all fixed system audible and visual alarms;
- .6 flow test all pumps for proper pressure and capacity;
- .7 test all antifreeze systems for adequate freeze protection;
- .8 test all system cross connections to other sources of water supply for proper operation;
- .9 verify all pump relief valves, if provided, are properly set;
- .10 examine all filters/strainers to verify they are free of debris and contamination;
- .11 verify all control/section valves are in the correct position;
- .12 blow dry compressed air or nitrogen through the discharge piping of dry pipe systems, or otherwise confirm the pipework and nozzles are clear of any obstructions. This may require the removal of nozzles, if applicable;
- .13 test emergency power supply switchover, where applicable;
- .14 visually inspect all sprinklers focusing in areas where sprinklers are subject to aggressive atmosphere (like saunas, spas, kitchen areas) and subject to physical damage (like luggage handling areas, gyms, play rooms, etc.) so that all sprinklers are inspected within one year;
- .15 check for any changes that may affect the system such as obstructions by ventilation ducts, pipes, etc.;
- .16 test a minimum of one section in each open head water mist system by flowing water through the nozzles. The sections tested should be chosen so that all sections are tested within a five-year period; and
- .17 test a minimum of two automatic sprinklers or automatic water mist nozzles for proper operation.

7.6 Ventilation systems and fire dampers

- .1 test all fire dampers for remote operation;
- .2 verify galley exhaust ducts and filters are free of grease build-up; and
- .3 test all ventilation controls interconnected with fire-protection systems for proper operation.

| | |
|--------------|--|
| Title | MSC Circulars / MSC.1/Circ.1432 |
| Note | This circular supersedes MSC/Circ.850. |

7.7 Fire doors

Test all remotely controlled fire doors for proper release.

7.8 Breathing apparatus

- 1 check breathing apparatus air recharging systems, if fitted, for air quality;
- 2 check all breathing apparatus face masks and air demand valves are in serviceable condition; and
- 3 check EEBDs according to maker's instructions.

7.9 Fixed dry chemical powder systems

- 1 visually inspect all accessible components for proper condition;
- 2 verify the pressure regulators are in proper order and within calibration; and
- 3 agitate the dry chemical powder charge with nitrogen in accordance with system manufacturer's instructions.

(Note: Due to the powder's affinity for moisture, any nitrogen gas introduced for agitation must be moisture free.)

7.10 Fixed aerosol extinguishing systems

Verify condensed or dispersed aerosol generators have not exceeded their mandatory replacement date. Pneumatic or electric actuators should be demonstrated working, as far as practicable.

7.11 Portable foam applicators

- 1 verify all portable foam applicators are set to the correct proportioning ratio for the foam concentrate supplied and the equipment is in proper order;
- 2 verify all portable containers or portable tanks containing foam concentrate remain factory sealed, and the manufacturer's recommended service life interval has not been exceeded;
- 3 portable containers or portable tanks containing foam concentrate, excluding protein based concentrates, less than 10 years old, that remain factory sealed can normally be accepted without the periodical foam control tests required in MSC.1/Circ.1312 being carried out;
- 4 protein based foam concentrate portable containers and portable tanks should be thoroughly checked and, if more than five years old, the foam concentrate should be subjected to the periodical foam control tests required in MSC.1/Circ.1312, or renewed; and
- 5 the foam concentrates of any non-sealed portable containers and portable tanks, and portable containers and portable tanks where production data is not documented, should be subjected to the periodical foam control tests required in MSC.1/Circ.1312.

7.12 Wheeled (mobile) fire extinguishers

- 1 perform periodical inspections in accordance with the manufacturer's instructions;
- 2 visually inspect all accessible components for proper condition;
- 3 check the hydrostatic test date of each cylinder; and
- 4 for dry powder extinguishers, invert extinguisher to ensure powder is agitated.

7.13 Galley and deep fat cooking fire-extinguishing systems

Check galley and deep fat cooking fire-extinguishing systems in accordance with the manufacturer's instructions.

8 Two-year testing and inspections

Two-year inspections should be carried out to ensure that the indicated actions are taken for the specified equipment.

| | |
|--------------|--|
| Title | MSC Circulars / MSC.1/Circ.1432 |
| Note | This circular supersedes MSC/Circ.850. |

8.1 Fixed gas fire-extinguishing systems

- .1 all high pressure extinguishing agents cylinders and pilot cylinders should be weighed or have their contents verified by other reliable means to confirm that the available charge in each is above 95 per cent of the nominal charge. Cylinders containing less than 95 per cent of the nominal charge should be refilled; and
- .2 blow dry compressed air or nitrogen through the discharge piping or otherwise confirm the pipe work and nozzles are clear of any obstructions. This may require the removal of nozzles, if applicable.

8.2 Fixed dry chemical powder systems

- .1 blow dry nitrogen through the discharge piping to confirm that the pipe work and nozzles are clear of any obstructions;
- .2 operationally test local and remote controls and section valves;
- .3 verify the contents of propellant gas cylinders (including remote operating stations);
- .4 test a sample of dry chemical powder for moisture content; and
- .5 subject the powder containment vessel, safety valve and discharge hoses to a full working pressure test.

9 Five-year service

At least once every five years, the following inspections should be carried out for the specified equipment.

9.1 Fixed gas fire-extinguishing systems

Perform internal inspection of all control valves.

9.2 Foam fire-extinguishing systems

- .1 perform internal inspection of all control valves;
- .2 flush all high expansion foam system piping with fresh water, drain and purge with air;
- .3 check all nozzles to prove they are clear of debris; and
- .4 test all foam proportioners or other foam mixing devices to confirm that the mixing ratio tolerance is within +30 to -10% of the nominal mixing ratio defined by the system approval.

9.3 Water mist, water spray and sprinkler systems

- .1 flush all ro-ro deck deluge system piping with water, drain and purge with air;
- .2 perform internal inspection of all control/section valves; and
- .3 check condition of any batteries, or renew in accordance with manufacturer's recommendations.

9.4 Breathing apparatus

Perform hydrostatic testing of all steel self-contained breathing apparatus cylinders. Aluminium and composite cylinders should be tested to the satisfaction of the Administration.

9.5 Low-location lighting

Test the luminance of all systems in accordance with the procedures in resolution A.752(18).

9.6 Wheeled (mobile) fire extinguishers

Visually examine at least one extinguisher of each type manufactured in the same year and kept on board.

10 Ten-year service

At least once every 10 years, the following inspections should be carried out for the specified equipment:

10.1 Fixed gas fire-extinguishing systems

Disclaimer : Although all possible efforts have been made to ensure correctness and completeness of the information contained in this Web Service, the Korean Register of Shipping is not responsible for any errors or omissions made herein, nor held for any actions taken by any party as a result of information retrieved from this Web Service.

E-mail : krcos@krs.co.kr

| | |
|--------------|--|
| Title | MSC Circulars / MSC.1/Circ.1432 |
| Note | This circular supersedes MSC/Circ.850. |

.1 perform a hydrostatic test and internal examination of 10 per cent of the system's extinguishing agent and pilot cylinders. If one or more cylinders fail, a total of 50 per cent of the onboard cylinders should be tested. If further cylinders fail, all cylinders should be tested;

.2 flexible hoses should be replaced at the intervals recommended by the manufacturer and not exceeding every 10 years; and

.3 if permitted by the Administration, visual inspection and NDT (non-destructive testing) of halon cylinders may be performed in lieu of hydrostatic testing.

10.2 Water mist, water spray and sprinkler systems

Perform a hydrostatic test and internal examination for gas and water pressure cylinders according to flag Administration guidelines or, where these do not exist, EN 1968:2002 + A1.

10.3 Fixed dry chemical powder systems

Subject all powder containment vessels to hydrostatic or non-destructive testing carried out by an accredited service agent.

10.4 Fixed aerosol extinguishing systems

Condensed or dispersed aerosol generators to be renewed in accordance with manufacturer's recommendations.

10.5 Wheeled (mobile) fire extinguishers

All extinguishers together with propellant cartridges should be hydrostatically tested by specially trained persons in accordance with recognized standards or the manufacturer's instructions.

KOREAN REGISTER

| | |
|--------------|------------------------------|
| Title | MSC Circulars / MSC/Circ.670 |
| Note | Refer to MSC/Circ.582 |

GUIDELINES FOR THE PERFORMANCE AND TESTING CRITERIA AND SURVEYS OF HIGH-EXPANSION FOAM CONCENTRATES FOR FIXED FIRE-EXTINGUISHING SYSTEMS

1 The Maritime Safety Committee, at its sixty-fourth session (5 to 9 December 1994), approved Guidelines for the performance and testing criteria and surveys of high-expansion foam concentrates for fixed fire-extinguishing systems, given in annex.

2 Member Governments are recommended to ensure that tests for type approval and periodical control of the high-expansion foam concentrates are performed in accordance with the annexed guidelines.

ANNEX

GUIDELINES FOR THE PERFORMANCE AND TESTING CRITERIA AND SURVEYS OF HIGH-EXPANSION FOAM CONCENTRATES FOR FIXED FIRE-EXTINGUISHING SYSTEMS

1 GENERAL

1.1 Application

These guidelines apply to the foam concentrates for fixed high-expansion foam fire-extinguishing systems referred to in SOLAS regulation II-2/9.

1.2 Definitions

For the purpose of these Guidelines the following definitions apply.

- (a) Foam (fire fighting): an aggregate of air filled bubbles formed from an aqueous solution of a suitable foam concentrate.
- (b) Foam solution: a solution of foam concentrate and water.
- (c) Foam concentrate: the liquid which, when mixed with water in the appropriate concentration, gives a foam solution.
- (d) Expansion ratio: the ratio of the volume of foam to the volume of foam solution from which it was made.
- (e) Spreading coefficient: a measurement of the ability of one liquid to spontaneously spread across another.
- (f) 25% (50%) drainage time: the time for 25% (50%) of the liquid content of a foam to drain out.
- (g) Gentle application: application of foam to the surface of a liquid fuel via a backboard, tank wall or other surface.
- (h) Sediment: insoluble particles in the foam concentrate.

2 SAMPLING PROCEDURE

The sampling method should ensure representative samples which should be stored in filled containers.

The sample size should be:

- 30 litres for type tests (see Section 3)
- 2 litres for periodical controls (see Section 4).

3 TESTS FOR TYPE APPROVAL OF FOAM CONCENTRATES

For foam concentrate type approval, the tests under paragraphs 3.1 - 3.10 should be performed. They should be carried out at laboratories acceptable to the Administration.

3.1 Freezing and thawing

3.1.1 Before and after temperature conditioning in accordance with 3.1.2, the foam concentrate should show

| | |
|--------------|------------------------------|
| Title | MSC Circulars / MSC/Circ.670 |
| Note | Refer to MSC/Circ.582 |

no visual sign of stratification, non-homogeneity or sedimentation.

3.1.2 Freezing and thawing test

(a) Apparatus:

- freezing chamber, capable of achieving temperatures required as stated in (b.1);
- polyethylene tube, approximately 10 mm diameter, 400 mm long and sealed and weighted at one end, with suitable spacers attached. Figure 1 shows a typical form;
- 500 mL cylinder approximately 400 mm high and 65 mm diameter.

(b) Procedure:

(b.1) Set the temperature of the freezing chamber to a temperature which is 10 °C below the freezing point of the sample measured in accordance with BS 5117: Section 1.3 (excluding 5.2 in the standard). To prevent the glass measuring cylinder from breaking, due to expansion of the foam concentrate on freezing, insert the tube into the measuring cylinder, sealed end downward, weighted if necessary to avoid flotation, the spacers ensuring it remains approximately on the central axis of the cylinder. Place the sample in the cylinder in the chest, cool and maintain at the required temperature for 24 h. At the end of this period thaw the sample for not less than 24 h and not more than 96 h in an ambient temperature of 20-25 °C.

(b.2) Repeat (b.1) three times to give four cycles of freezing and thawing.

(b.3) Examine the sample for stratification and non-homogeneity.

(b.4) Condition the sample for 7 days at 60 °C followed by one day at room temperature.

3.2 Heat stability

An unopened 20 litre container (or other standard shipping container) as supplied by the manufacturer from a production batch should be maintained for 7 days- at 60°C, followed by one day at room temperature. Following this conditioning, the foam liquid after agitating/stirring will be subjected to the fire test as per 3.8, and comply with the requirements given in these guidelines.

3.3 Sedimentation

3.3.1 Any sediment in the concentrate prepared in accordance with Section 2 should be dispersible through a 180 µm sieve, and the percentage volume of sediment should not be more than 0,25% when tested in accordance with 3.3.2.

3.3.2 The test should be carried out as follows:

(a) Apparatus:

- graduated centrifuge tubes;
- centrifuge operating at 6000 +/- 100 m/s²;
- 180 micro m sieve complying with ISO 3310-1;
- plastic wash bottle.

NOTE: A centrifuge and tubes complying with ISO 3734 are suitable.

(b) Procedure:

Centrifuge each sample for 10 min. Determine the volume of the sediment and determine the percentage of this volume with respect to the centrifuged sample volume. Wash the contents of the centrifuge tube onto the sieve and check that the sediment can or cannot be dispersed through the sieve by the jet from the plastic wash bottle.

NOTE: It is possible that the test method is not suitable for some non-Newtonian foam concentrates. In this case an alternative method, to the satisfaction of the Administration, should be used so that

| | |
|--------------|------------------------------|
| Title | MSC Circulars / MSC/Circ.670 |
| Note | Refer to MSC/Circ.582 |

compliance with this requirement can be verified.

3.4 Kinematic viscosity

3.4.1 The test should be carried out according to ASTM D 445-86 or ISO 3104. Kinematic viscosity should not exceed 200 mm² /s.

3.4.2 The method for determining viscosity of non-Newtonian foam concentrates should be to the satisfaction of the Administration.

3.5 Ph value

The pH of the foam concentrate prepared in accordance with Section 2 should be not less than 6.0 and not more than 9.5 at 20 +/- 2) °C.

3.6 Expansion ratio

3.6.1 The test should be carried out according to paragraph 3.6.2, with sea water at about 20 °C. Simulated sea water with the characteristics stated under 3.6.3 may be used. The expansion ratio obtained with the foam generators used on board should be consistent with the expansion ratio obtained with the foam generators during the fire test.

3.6.2 Determination of the expansion ratio

(a) Apparatus:

- plastic collecting vessel of volume V, approximately 500 L and accurately known to +/- 5 L;
- high expansion foam-making equipment which when tested with water has a flow rate of 6.1 +/- 0.1 L/min at a nozzle pressure of (5.0 +/- 0.1) bar. An example for a suitable apparatus is given in document ISO 7203-2.

(b) Procedure:

(b.1) Wet the vessel internally and weigh it (W 1). Set up the foam equipment and adjust the nozzle pressure to give a flow rate of 6.1 L/min. With the discharge facility closed, collect foam in the vessel. As soon as the vessel is full, stop collecting foam and strike the foam surface level with the rim. Weigh the vessel (W 2). During the filling operation, keep this discharge facility in the bottom of the vessel closed until the total weight of the foam is determined.

(b.2) Calculate the expansion E from the equation:

in which it is assumed that the density of the foam solution is 1.0 kg/L and where:

V is the vessel volume, in ml;

W 1 is the mass of the empty vessel, in grammes;

W 2 is the mass of the full vessel, in grammes.

Assume that the density of the foam solution is 1.0 kg/L.

(b.3) Open the drainage facility and measure the 50% drainage time (see para3.7.1 hereinafter).

Determine the drainage either by having the vessel on a scale and recording the weight loss, or by collecting the drained foam solution in a measuring cylinder. Care should be taken to ensure that there are no voids in the foam collected in the vessel.

3.6.3 Simulated sea water may be made up by dissolving

25.0 g Sodium chloride (NaCl)

11.0 g Magnesium chloride (MgCl₂·6H₂O)

| | |
|--------------|------------------------------|
| Title | MSC Circulars / MSC/Circ.670 |
| Note | Refer to MSC/Circ.582 |

1.6 g Calcium chloride (CaCl₂·2H₂O)

4.0 g Sodium sulphate (Na₂SO₄)

in each litre of potable water.

3.7 Drainage time

3.7.1 The drainage time should be determined, after having determined the expansion ratio, according to paragraph 3.6.2(b.3).

3.7.2 The test should be carried out with sea water at about 20°C. Simulated sea water with the characteristics stated in 3.6.3 may be used.

3.7.3 Drainage time obtained with the foam generators used on board should be consistent with the drainage time obtained with the foam generators during the fire test.

3.8 Fire tests

Fire tests should be carried out according to the following paragraphs 3.8.1 to 3.8.7.

NOTE: The fire tests of section 3.8 are more expensive and time consuming than the other tests of these guidelines. It is recommended that fire tests should be carried out at the end of the test programme, so as to avoid expense of unnecessary testing of foam concentrates which do not comply in other respects.

3.8.1 Environmental conditions

- Air temperature : (15 +/- 5) °C
- Maximum wind speed : 3 m/s in proximity of the fire tray

3.8.2 Records

During the fire test, record the following:

- indoor or outdoor test
- air temperature
- fuel temperature
- water temperature.
- foam solution temperature
- wind speed
- extinction time.

3.8.3 Foam solution

(a) Prepare a foam solution, following the recommendations from the supplier for concentration, maximum premix time, compatibility with the test equipment, avoiding contamination by other types of foam, etc.

(b) The test should be carried out with sea water at about 20 °C. Simulated sea water with the characteristics stated in 3.6.3 may be used.

3.8.4 Apparatus

(a) Fire tray:

Circular fire tray of steel with dimensions as follows:

diameter at rim : (1,480 +/- 15) mm

depth: (150 +/- 10) mm

nominal thickness of steel wall: 2.5 mm

| | |
|--------------|------------------------------|
| Title | MSC Circulars / MSC/Circ.670 |
| Note | Refer to MSC/Circ.582 |

NOTE: The tray has an area of approximately 1.73 m².

(b) Foam-making equipment:

In accordance with subparagraph 3.6.2(a).

(c) Fire screens:

Fire screens of nominal 5 mm square metal mesh to form the nominal arrangement mentioned in subparagraph 3.8.6.

3.8.5 Fuel

Use an aliphatic hydrocarbon mixture with physical properties according to the following specification

- distillation range : 84 °C-105 °C
- maximum difference between initial and final boiling points : 10 °C
- maximum aromatic content: 1%
- density at 15 °C : (707.5 +/- 2.5) kg/m³
- temperature: about 20 °C

NOTE: Typical fuels meeting this specification are n-heptane and certain solvent fractions sometimes referred to as commercial heptane.

The Administration may require additional fire tests using an additional test fuel.

3.8.6 Test procedure

(a) Place the tray directly on the ground and ensure that it is level. Add approximately 30 litres of sea water, or simulated sea water with the characteristics stated in 3.6.3, and (55 +/- 5) litres of fuel, to give a nominal freeboard of 100 mm.

(b) Place the net screens around the fire tray as shown in figure 2. Within 5 min ignite the fuel and allow it to burn for a period of not less than 45 s. Commence foam generation with the foam generator some distance from the fire. (60 +/- 5) s after full involvement move the foam generator to the opening between the net screen and apply foam to the fire. Apply foam for a period of (120 +/- 2) s. Record the extinction time as the period from start of foam application to extinction.

3.8.7 Permissible limits

extinction time: not more than 120 s

3.9 Corrosiveness

The storage container shall be compatible with its foam concentrate, throughout the service life of the foam, such that the chemical and physical properties of the foam shall not deteriorate below the initial values accepted by the Administration.

3.10 Volumic mass

According to ASTM D 1298-85.

4 PERIODICAL CONTROLS OF FOAM CONCENTRATES STORED ON BOARD

The attention of the Administration is drawn to the fact that particular installation conditions (excessive ambient temperature, incomplete filling of the tank etc.) may lead to an abnormal aging of the concentrates. For the periodical control of foam concentrate the tests under paragraphs 4.1 - 4.5 should be performed. They should be carried out at laboratories acceptable to the Administration.

The deviations in the values obtained by these tests, in respect of those obtained during the type approval tests, should be within ranges acceptable to the Administration. Tests under items 4.1, 4.3 and 4.4 should be carried out on samples maintained at 60 °C or 24 hours and subsequently cooled to the test temperature.

Disclaimer : Although all possible efforts have been made to ensure correctness and completeness of the information contained in this Web Service, the Korean Register of Shipping is not responsible for any errors or omissions made herein, nor held for any actions taken by any party as a result of information retrieved from this Web Service.

E-mail : krcon@krs.co.kr

| | |
|--------------|------------------------------|
| Title | MSC Circulars / MSC/Circ.670 |
| Note | Refer to MSC/Circ.582 |

4.1 Sedimentation

According to paragraph 3.3 above.

4.2 pH value

According to paragraph 3.5 above.

4.3 Expansion ratio

According to paragraph 3.7 above.

4.4 Drainage time

According to paragraph 3.8 above.

4.5 Volumic mass

According to paragraph 3.10 above.

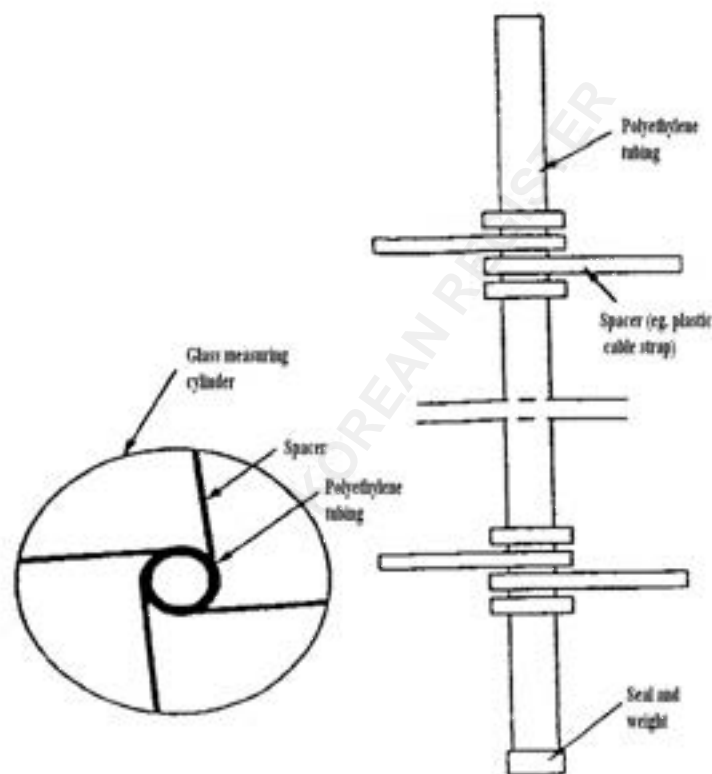

Figure 1
Typical form of polyethylene tube

5 INTERVAL OF PERIODICAL CONTROLS

The first periodical control of foam concentrates stored on board should be performed after a period of 3 years and, after that, every year.

A record of the age of the foam concentrates and of subsequent controls should be kept on board.

| | |
|-------|------------------------------|
| Title | MSC Circulars / MSC/Circ.670 |
| Note | Refer to MSC/Circ.582 |



Figure 2 - Fire test arrangement

KOREAN REGISTER

GUIDELINES FOR PERFORMANCE AND TESTING CRITERIA AND SURVEYS OF MEDIUM-EXPANSION CONCENTRATES FOR FIRE-EXTINGUISHING SYSTEMS

1 The Maritime Safety Committee, at its sixty-eighth session, approved the guidelines for the performance and testing criteria and surveys of medium-expansion foam concentrates for fire-extinguishing systems as contained in the annex.

2 Member Governments are recommended to ensure that tests for type approval and periodical control of the medium-expansion foam concentrates are performed in accordance with the attached guidelines.

ANNEX

1 GENERAL

1.1 Application

These guidelines apply to the foam concentrates for medium-expansion foam fire-extinguishing systems referred to in SOLAS regulation II-2/61.

1.2 Definitions

For the purpose of these Guidelines the following definitions apply:

1.2.1 "Foam (fire fighting)": an aggregate of air filled bubbles formed from an aqueous solution of a suitable foam concentrate;

1.2.2 "Foam solution": a solution of foam concentrate and water;

1.2.3 "Foam concentrate": the liquid which, when mixed with water in the appropriate concentration, gives a foam solution;

1.2.4 "Expansion ratio": the ratio of the volume of foam to the volume of foam solution from which it was made;

1.2.5 "Spreading coefficient": a measurement of the ability of one liquid to spontaneously spread across another;

1.2.6 "25% (50%) drainage time": the time for 25% (50%) of the liquid content of a foam to drain out;

1.2.7 "Gentle application": application of foam to the surface of a liquid fuel via a backboard, tank wall or other surface;

1.2.8 "Sediment": insoluble particles in the foam concentrate.

2 SAMPLING PROCEDURE

2.1 The sampling method should ensure representative samples which should be stored in filled containers.

2.2 The sample size should be:

.1 30 litres for type tests (see Section 3)

.2 2 litres for periodical controls (see Section 4)

3 TESTS FOR TYPE APPROVAL OF FOAM CONCENTRATES

For foam concentrate type approval, the tests under paragraphs 3.1 to 3.10 should be performed. They should be carried out at laboratories acceptable to the Administration.

3.1 Freezing and thawing

3.1.1 Before and after temperature conditioning in accordance with 3.1.2, the foam concentrate should show no visual sign of stratification, non-homogeneity or sedimentation.

3.1.2 Freezing and thawing test

.1 Apparatus:

- .1 freezing chamber, capable of achieving temperatures required as stated in 2.1 below;
- .2 polyethylene tube, approximately 10 mm diameter, 400 mm long and sealed and weighted at one end, with suitable spacers attached (Figure 1 of MSC/Circ.582 shows a typical form.)
- .3 500 mL cylinder approximately 400 mm high and 65 mm diameter.

.2 Procedure:

- .1 Set the temperature of the freezing chamber to a temperature which is 10 degrees C below the freezing point of the sample measured in accordance with BS 5117: Section 1.3 (excluding 5.2 in the standard).

To prevent the glass measuring cylinder from breaking, due to expansion of the foam concentrate on freezing, insert the tube into the measuring cylinder, sealed end downward, weighted if necessary to void floatation, the spacers ensuring it remains approximately on the central axis of the cylinder. Place the sample in the cylinder in the chest, cool and maintain at the required temperature for 24 hours. At the end of this period thaw the sample for not less than 24 hours and not more than 96 hours in an ambient temperature of 20-25 degrees C.

- .2 Repeat .2.1 three times to give four cycles of freezing and thawing.
- .3 Examine the sample for stratification and non-homogeneity.
- .4 Condition the sample for 7 days at 60 degrees C followed by one day at room temperature.

3.2 Heat stability

An unopened 20 litre container (or other standard shipping container) as supplied by the manufacturer from a production batch should be maintained for 7 days at 60 degrees C, followed by one day at room temperature. Following this conditioning, the foam liquid after agitating/stirring will be subjected to the fire test as per 3.8, and comply with the requirements given in these guidelines.

3.3 Sedimentation

3.3.1 Any sediment in the concentrate prepared in accordance with Section 2 should be dispersible through a 180 micro m sieve, and the percentage volume of sediment should not be more than 0.25% when tested in accordance with 3.3.2.

3.3.2 The test should be carried out as follows:

.1 Apparatus:

- .1 graduated centrifuge tubes;
- .2 centrifuge operating at 6000 +/- 100 m/s**2;
- .3 180 micro m sieve complying with ISO 3310-1;
- .4 plastic wash bottle.

NOTE : A centrifuge and tubes complying with ISO 3734 are suitable.

.2 Procedure:

Centrifuge each sample for 10 minutes. Determine the volume of the sediment and determine the percentage of this volume with respect to the centrifuged sample volume. Wash the contents of the centrifuge tube onto the sieve and check that the sediment can or cannot be dispersed through the sieve by the jet from the plastic wash bottle.

NOTE : It is possible that the test method is not suitable for some non-Newtonian foam concentrates. In this case an alternative method, to the satisfaction of the Administration, should be used so that compliance with this requirement can be verified.

3.4 Kinematic viscosity

3.4.1 The test should be carried out according to ASTM D 445-86 or ISO 3104. Kinematic viscosity should not exceed 200 mm**2/s.

3.4.2 The method for determining viscosity of non-Newtonian foam concentrates should be to the satisfaction of the Administration.

3.5 pH value

The pH value of the foam concentrate should be not less than 6.0 and not more than 10.0 at temperature of 20 +/- 2 degrees C.

3.6 Expansion ratio

3.6.1 The test should be carried out in accordance with paragraph 3.6.2 with sea water at about 20 degrees C. Simulated sea water with the characteristics stated under 3.6.3 may be used. The expansion ratio obtained with the foam generators used on board should be consistent with the expansion ratio obtained with the foam generators during the fire test.

3.6.2 Determination of the expansion ratio:

.1 Apparatus:

.1 plastic collecting vessel of volume V, approximately 200 L and accurately known to +/- 2 L;

(An example of suitable vessel is given in ISO 7203-2)

.2 medium-expansion foam-making equipment which when tested with water has a flow rate not less than (3.0 +/- 0.1) L/min at a nozzle pressure of (5.0 +/- 0.1) bar.

(An example of suitable apparatus is given in ISO 7203-2).

.2 Procedure

.1 Wet the vessel internally and weight it (W1). Set up the foam equipment and adjust the nozzle pressure of (5.0 +/- 0.1) bar. With the discharge facility closed, collect the foam in the vessel. As soon as the vessel is full, stop collecting foam and strike the foam surface level with the rim. Weight the vessel (W2). During the filling operation, keep the discharge facility in the bottom of the vessel closed until the total weight of the foam is determined.

.2 Calculate the expansion E from the equation:

$$E = V/(W2 - W1)$$

where it is assumed that the density of the foam solution is 1.0 kg/L;

V is the vessel volume, in mL;

W1 is the mass of the empty vessel, in grammes; and

W2 is the mass of the full vessel, in grammes.

.3 Open the drainage facility and measure the 50% drainage time (see paragraph 3.7.1 below).

Determine the drainage either by having the vessel on a scale and recording the weight loss, or by collecting the drained foam solution in a measuring cylinder.

3.6.3 Simulated sea water may be made up by dissolving:

25.0 g Sodium chloride (NaCl)

11.0 g Magnesium chloride (MgCl₂ 6H₂O)

1.6 g Calcium chloride (CaCl₂ 2H₂O)

4.0 g Sodium sulphate (Na₂SO₄)

3.7 Drainage time

3.7.1 The drainage time should be determined, after having determined the expansion ratio, in accordance with paragraph 3.6.2.3.

3.7.2 The test should be carried out with sea water at about 20 degrees C. simulated sea water with the characteristics stated in 3.6.3 may be used.

3.7.3 Drainage time obtained with the foam generators used on board should be consistent with the drainage time obtained with the foam generators during the fire test.

3.8 Fire tests

Fire tests should be carried out in accordance with the following paragraphs 3.8.1 - 3.8.7 below.

NOTE : The fire tests of section 3.8 are more expensive and time consuming than the other tests of these guidelines. It is recommended that fire tests should be carried out at the end of the test programme, so as to avoid expense of unnecessary testing of foam concentrates which do not comply in other respects.

3.8.1 Environmental conditions

- .1 Air temperature: (15 +/- 5) degrees C
- .2 Maximum wind speed: 3 m/s in proximity of the fire tray.

Records

During the fire test, record the following:

- .1 indoor or outdoor test
- .2 air temperature
- .3 fuel temperature
- .4 water temperature
- .5 foam solution temperature
- .6 wind speed
- .7 extinction time.

3.8.3 Foam solution

- .1 Prepare a foam solution, following the recommendations from the supplier for concentration, maximum premix time, compatibility with the test equipment, avoiding contamination by other types of foam, etc.
- .2 The test should be carried out with sea water at about 20 degrees C. Simulated sea water with the characteristics stated in 3.6.3 may be used.

3.8.4 Apparatus

- .1 Fire tray:

Circular fire tray of steel with dimensions as follows:

- diameter at rim: (1,480 +/- 15) mm
- depth (150 +/- 10) mm
- normal thickness of steel wall 2.5 mm

NOTE : The tray has an area of approximately 1.73 m**2.

- .2 Foam-making equipment:

In accordance with subparagraph 3.6.2.1.

3.8.5 Fuel

Use an aliphatic hydrocarbon mixture with physical properties according to the following specification:

- .1 distillation range 84-105 degrees
- .2 maximum difference between initial and boiling points 10 degrees C
- .3 maximum aromatic content 1%
- .4 density at 15 degrees (707.5 +/- 2.5) kg/m**3

.5 temperature about 20 degrees C.

NOTE : Typical fuels meeting this specification are n-heptane and certain solvent fractions sometimes referred to as commercial heptane.

The Administration may require additional fire tests using an additional test fuel.

3.8.6 Test procedure

3.8.6.1 Place the tray directly on the ground and ensure that it is level. Add approximately 30L of fresh water and (55 +/- 2) L of fuel, to give a nominal freeboard of 100 mm.

3.8.6.2 Not later than 5 minutes after adding of a fuel, ignite the fuel and allow it to burn free for a period of not less than 180 s after the full involvement. Set up the foam equipment at a height which is equal to the upper edge of the rim as it is shown at figure 1. 200 +/-5 s after full involvement of the surface into the fire, apply foam along the wall of the tray for a period of 120 +/- 2 s. Record the extinction time as the period from start of foam application to extinction.

3.8.7 Permissible limits

Extinction time % not more than 120 s.

3.9 Corrosiveness

The storage container shall be compatible with its foam concentrate, throughout the service life of the foam, such that the chemical and physical properties of the foam shall not deteriorate below the initial values accepted by the Administration.

3.10 Volumic mass

According to ASTM D 1298-85.

4 PERIODICAL CONTROLS OF FOAM CONCENTRATES STORED ON BOARD

The attention of the Administration is drawn to the fact that particular installation conditions (excessive ambient temperature, incomplete filling of the tank etc.) may lead to an abnormal ageing of the concentrates. For the periodical control of foam concentrate the tests under paragraphs 4.1 to 4.5 should be performed. They should be carried out at laboratories acceptable to the Administration. The deviations in the values obtained by these tests, in respect of those obtained during the type approval tests, should be within ranges acceptable to the Administration. Tests under items 4.1, 4.3 and 4.4 should be carried out on samples maintained at 60 degrees C for 24 hours and subsequently cooled to the test temperature.

4.1 Sedimentation

According to paragraph 3.3 above.

4.2 pH value

According to paragraph 3.5 above.

4.3 Expansion ratio

According to paragraph 3.6 above.

4.4 Drainage time

According to paragraph 3.7 above.

4.5 Volumic mass

According to paragraph 3.10 above.

5 INTERVALS OF PERIODICAL CONTROLS

The first periodical control of foam concentrates stored on board should be performed after a period of 3 years and, after that, every year. A record of the age of the foam concentrates and of subsequent controls should be kept on board.

Figure 1 - Fire test arrangement of medium expansion foam

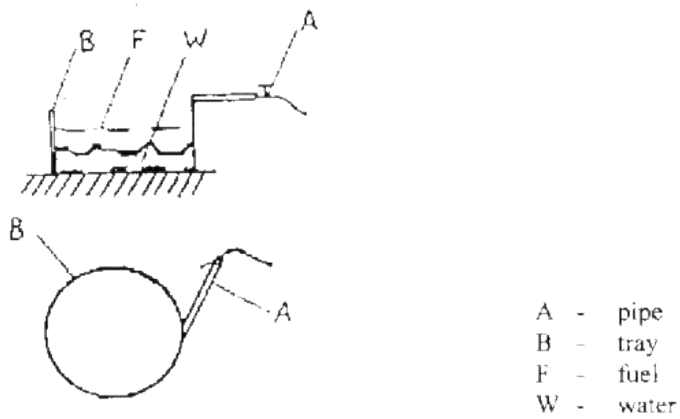

Figure 1- Fire test arrangement of medium expansion foam

KOREAN REGISTER

INTERNATIONAL MARITIME ORGANIZATION

INTERPRETATIONS OF VAGUE EXPRESSIONS AND OTHER VAGUE WORDING IN SOLAS CHAPTER II-2

Corrigenda

The following modifications are made to the interpretations contained in the annex to document MSC/Circ.847:

- 1 In regulation 18.1.1, interpretation 2, the word "interpretations"" is replaced by "interpretation 2".
- 2 In regulation 27.2, "interpretation2" is replaced by "interpretations".
- 3 In regulation 29.2, interpretation1, the word "interpretations""is replaced by "interpretation1"
- 4 In regulation 32.1.9.2, interpretation 1, the word "interpretations" is replaced by "interpretation".
- 5 In regulation 32.1.9.5, interpretation 1, the sentence "(See also interpretations of regulation II-2/41-2.4.3.5)" is added at the end of the interpretation.
- 6 In regulation 33.2, the existing text of the interpretation is replaced by the following:
"33.2 Reference is made to the following ISO standards:
ISO 614:1989 Shipbuilding and marine structures - Toughened safety glass panes for rectangular windows and side scuttles - Punch method of non-destructive strength testing
ISO 1095:1989 Shipbuilding and marine structures - Toughened safety glass panes for side scuttles
ISO 1751:1993 Shipbuilding and marine structures - Ships' side scuttles
ISO 3254:1989 Shipbuilding and marine structures - Toughened safety glass panes for rectangular windows
ISO 3903:1993 Shipbuilding and marine structures - Ships' ordinary rectangular windows
ISO 3904:1990 Shipbuilding and marine structures - Clear-view screens
- 7 In regulation 34.1, interpretation 2, the word "interpretations""is replaced by "interpretation1".
- 8 In regulation 34.6, interpretation 1, the word "interpretations"" is replaced by "interpretation1".
- 9 In regulation 34.6, interpretation 2, the word "interpretations"" is replaced by "interpretation2".
- 10 In regulation 37.1.5.3, interpretation 1, the sentence "(See also interpretations of regulation II-2/38.2.3)"" is added at the end of the interpretation.
- 11 In regulation 37.1.6.3, the word "interpretations"" is replaced by "interpretation".
- 12 In regulation 37.1.6.4, the word "interpretations"" is replaced by "interpretation".
- 13 In regulation 37.3.2.2, interpretation 1, the sentence "(See also interpretations of regulations II-2/37.2.2.2 and 38.4.2)" is added at the end of the interpretation.
- 14 In regulation 38.3.3, the word "interpretations"" is replaced by "interpretation".
- 15 In regulation 38.3.4, the word "interpretations"" is replaced by "interpretation".
- 16 In regulation 38.4.1, the word "interpretations"" is replaced by "interpretation".
- 17 In regulation II-2/41-2.4.5, the existing heading is replaced by "Escape stairway from machinery spaces".
- 18 In regulation II-2/41-2.4.5, the sentence "(See also interpretation 2 of regulation II-2/29.2)"" is deleted.
- 19 In regulation II-2/44.2, the words "interpretation to" are replaced by "interpretation 2 of".
- 20 In regulation II-2/44.2, the number "27.2"" is deleted.
- 21 In regulation 45.3.1, interpretation 1, the sentence "One of the means of escape required by regulation II-2/45.3.1 should be arranged as follows:"" is replaced by "If a shelter is provided, it should be arranged as

| | |
|-------|--------------------------------|
| Title | MSC Circulars / MSC/Circ.847c1 |
|-------|--------------------------------|

follows:"

22 In regulation 54.2.5, interpretation 3, the second sentence is replaced by the following: "Electrical equipment in the space should comply with the International Standard IEC Publication 92-506: Electrical installations in ships - Part 506: Special features - Ships carrying specific dangerous goods and materials hazardous only in bulk."

23 In table 58.2, note e, the words "the interpretation of" are deleted.

KOREAN REGISTER

IMO

GUIDELINES FOR THE PERFORMANCE, LOCATION, USE AND CARE OF EMERGENCY ESCAPE BREATHING DEVICES (EEBDs)

1 The Maritime Safety Committee, at its sixty-ninth session (II to 20 May 1998), noting that it had approved, in principle, proposed draft amendments to SOLAS chapter 11-2 to require the carriage of emergency escape breathing devices (EEBDs) on all ships, for inclusion in future amendments to the 1974 SOLAS Convention, approved Guidelines for the performance, location, use and care of emergency escape breathing devices (EEBDs), as set out in the annex.

2 Member Governments are invited, pending adoption by the MSC and entry into force of the aforementioned proposed amendments to the 1974 SOLAS Convention, to bring the annexed Guidelines to the attention of shipowners, shipmasters, ships' officers and crew and all other parties concerned.

ANNEX

GUIDELINES FOR THE PERFORMANCE, LOCATION, USE AND CARE OF EMERGENCY ESCAPE BREATHING DEVICES (EEBDs)

1 SCOPE

1.1 These Guidelines provide information and guidance on the location, use, and care of emergency escape breathing devices (EEBDs), to provide personnel breathing protection against a hazardous atmosphere while escaping to an area of safety.

2 GENERAL

2.1 An EEBD is a supplied-air or oxygen device only used for escape from a compartment that has a hazardous atmosphere and should be of approved type.

2.2 EEBDs are not to be used for fighting fires, entering oxygen deficient voids or tanks, or worn by fire-fighters. In these events, a self-contained breathing apparatus, which is specifically suited for such situations should be used.

3 DEFINITIONS

3.1 "Face piece" means a face covering that is designed to form a complete seal around the eyes, nose and mouth which is secured in position by a suitable means.

3.2 "Hood" means a head covering which completely covers the head, neck, and may cover portions of the shoulders.

3.3 "Hazardous atmosphere" means any atmosphere that is immediately dangerous to life or health.

4 PARTICULARS

4.1 The EEBD should have at least a duration of service of 10 min.

4.2 The EEBD should include a hood or full face piece, as appropriate, to protect the eyes, nose and mouth during escape. Hoods and face pieces should be constructed of flame resistant materials, and include a clear window for viewing.

4.3 An unactivated EEBD should be capable of being carried hands-free.

4.4 The EEBDs, when stored, should be suitably protected from the environment.

4.5 Brief instructions or diagrams clearly illustrating the use should be clearly printed on the EEBD. The donning procedures should be quick and easy to allow for situations where there is little time to seek safety from a hazardous atmosphere.

4.6 Unless personnel are individually carrying EEBDs, consideration should be given for placing such devices

| | |
|-------|------------------------------|
| Title | MSC Circulars / MSC/Circ.849 |
|-------|------------------------------|

along the escape routes within the machinery spaces or at the foot of each escape ladder within the space. In addition, control spaces and workshops located within the machinery spaces should also be considered for the possible location of such devices

5 CARE

5.1 The EEBD should be maintained in accordance with the manufacturer's instructions

5.2 Spare EEBDs should be kept on board.

5.3 Maintenance requirements, manufacturer's trademark and serial number, shelf life with accompanying manufacture date and name of approving authority should be printed on each EEBD.

6 TRAINING

6.1 Training in the use of the EEBD should be considered as a part of basic safety training.

6.2 All EEBD training units should be clearly marked.

6.3 Personnel should be trained to immediately don an EEBD prior to exiting a space when the atmosphere becomes life threatening. This is necessary due to the possibility of encountering smoke during escape. Such training should be accomplished by scheduling routine escape drills for crew members working in the engineering or machinery spaces.

6.4 An EEBD may also be used to escape from a machinery space due to an accidental release of a fixed CO2 system and can be carried by fire-fighters for the sole purpose of providing the device to personnel in need of emergency assistance.

KOREAN REGISTER

| | |
|--------------|---|
| Title | RESOLUTIONs / Assembly / 23rd Session / Res.A.951(23) |
| Note | Revokes Res.A.602(15) |

INTERNATIONAL MARITIME ORGANIZATION

Resolution A.951(23)

Adopted on 5 December 2003

(Agenda item 17)

IMPROVED GUIDELINES FOR MARINE PORTABLE FIRE EXTINGUISHERS

THE ASSEMBLY,

RECALLING Article 15(j) of the Convention on the International Maritime Organization concerning the functions of the Assembly in relation to regulations and guidelines concerning maritime safety,

RECALLING ALSO that, by resolution A.602(15), it adopted the Revised Guidelines for Marine Portable Fire Extinguishers, to supplement the relevant requirements of chapter II-2 of the International Convention for the Safety of Life at Sea (SOLAS), 1974, as amended, as well as chapter V of the Torremolinos International Convention for the Safety of Fishing Vessels, 1977,

RECOGNIZING the need to further improve the said Revised Guidelines following the adoption of amendments to chapter II-2 of the 1974 SOLAS Convention and of the 1993 Torremolinos Protocol to the 1977 Torremolinos Convention referred to above, and in the light of the experience gained from the application of the Revised Guidelines,

HAVING CONSIDERED the recommendation made by the Maritime Safety Committee at its seventy-fifth session,

1. ADOPTS the Improved Guidelines for Marine Portable Fire Extinguishers, the text of which is set out in the Annex to the present resolution;
2. RECOMMENDS Governments concerned to apply the annexed Improved Guidelines in conjunction with the appropriate requirements of the international instruments referred to above;
3. AUTHORIZES the Maritime Safety Committee to keep the Improved Guidelines under review and amend or extend them as necessary;
4. REVOKES resolution A.602(15).

ANNEX

IMPROVED GUIDELINES FOR MARINE PORTABLE FIRE EXTINGUISHERS

1 Scope

These Guidelines have been developed to supplement the relevant requirements for marine portable fire extinguishers* of the International Convention for the Safety of Life at Sea 74, as amended, the International Code for Fire Safety Systems (FSS Code) and the 1993 Torremolinos Protocol relating to the Torremolinos International Convention for the Safety of Fishing Vessels, 1977. The Guidelines are offered to Administrations to assist them in determining appropriate design and construction parameters. The status of the Guidelines is advisory. Their content is based on current practices and does not exclude the use of designs and materials other than those indicated below.

2 Definitions

2.1 An extinguisher is an appliance containing an extinguishing medium, which can be expelled by the action of

Disclaimer : Although all possible efforts have been made to ensure correctness and completeness of the information contained in this Web Service, the Korean Register of Shipping is not responsible for any errors or omissions made herein, nor held for any actions taken by any party as a result of information retrieved from this Web Service.

E-mail : krcon@krs.co.kr

| | |
|--------------|---|
| Title | RESOLUTIONS / Assembly / 23rd Session / Res.A.951(23) |
| Note | Revokes Res.A.602(15) |

internal pressure and be directed into a fire. This pressure may be stored pressure or be obtained by release of gas from a cartridge.

2.2 A portable extinguisher is one, which is designed to be carried and operated by hand, and which in working order has a total weight of not more than 23 kg.

2.3 Extinguishing medium is the substance contained in the extinguisher which is discharged to cause extinction of fire.

2.4 Charge of an extinguisher is the mass or volume of the extinguishing medium contained in the extinguisher. The quantity of the charge of water or foam extinguishers is normally expressed in volume (litres) and that of other types of extinguishers in mass (kilograms).

3 Classification

3.1 Extinguishers are classified according to the type of extinguishing medium they contain. At present the types of extinguishers and the uses for which they are recommended are as follows:

| Extinguishing medium | Recommended for use on fires involving |
|---|--|
| Water Water with additives | wood, paper, textiles and similar materials |
| Foam | wood, paper, textiles and flammable liquids |
| Dry powder/dry chemical (standard/ classes B, C) | flammable liquids, electrical equipment and flammable gases |
| Dry powder/dry chemical (multiple or general purpose/classes A, B, C) | wood, paper, textiles, flammable liquids, electrical equipment and flammable gases |
| Dry powder/dry chemical (metal) | combustible metals |
| Carbon dioxide | flammable liquids and electrical equipment |
| Wet chemical for class F or K | cooking grease, fats or oil fires |
| Clean agents** | |

* Wherever in the text of these Guidelines the word "portable extinguisher" appears it should be taken as meaning "marine portable fire extinguisher".

** Refer to the recommendations by the International Organization for Standardization, in particular Publication ISO 7165:1999, Fire-fighting - Portable fire extinguishers - Performance and construction.

3.2 A table is provided in the appendix which describes the general characteristics of each type of extinguisher.

4 Construction

4.1 The construction of an extinguisher should be designed and manufactured for simple and rapid operation, and ease of handling.

4.2 Extinguishers should be manufactured to a recognized national or international standard*, which includes a requirement that the body, and all other parts subject to internal pressure, be tested:

.1 to a pressure of 5.5 MPa or 2.7 times the normal working pressure, whichever is the higher, for extinguishers with a service pressure not exceeding 2.5 MPa; or

.2 in accordance with the recognized standard for extinguishers with a service pressure exceeding 2.5 MPa.

4.3 In the design of components, selection of materials and determination of maximum filling ratios and densities, consideration should be given to the temperature extremes to which extinguishers may be exposed on board ships and operating temperature ranges specified in the recognized standards.

4.3 The materials of construction of exposed parts and adjoining dissimilar metals should be carefully selected to function properly in the marine environment.

5 Fire classifications

Disclaimer : Although all possible efforts have been made to ensure correctness and completeness of the information contained in this Web Service, the Korean Register of Shipping is not responsible for any errors or omissions made herein, nor held for any actions taken by any party as a result of information retrieved from this Web Service.

E-mail : krcon@krs.co.kr

| | |
|--------------|---|
| Title | RESOLUTIONS / Assembly / 23rd Session / Res.A.951(23) |
| Note | Revokes Res.A.602(15) |

5.1 Fire classifications are generally indicated as A, B, C, D and F (or K). There are currently two standards, defining classes of fires according to the nature of the material undergoing combustion, as follows:

| International Organization for Standardization (ISO standard 3941)* | National Fire Protection Association (NFPA 10) |
|---|---|
| Class A: Fires involving solid materials, usually of an organic nature, in which combustion normally takes place with the formation of glowing embers. | Class A: Fires in ordinary combustible materials such as wood, cloth, paper, rubber and many plastics. |
| Class B: Fires involving liquids or liquefiable solids. | Class B: Fires in flammable liquids, oils, greases, tars, oil base paints, lacquers and flammable gases. |
| Class C: Fires involving gases. | Class C: Fires, which involve energized electrical equipment where the electrical non-conductivity of the extinguishing medium is of importance. (When electrical equipment is de-energized, extinguishers for class A or B fires may be used safely.) |
| Class D: Fires involving metals. | Class D: Fires in combustible metals such as magnesium, titanium, zirconium, sodium, lithium and potassium. |
| Class F: Fires involving cooking oils. | Class K: Fires involving cooking grease, fats and oils. |

*Comite European de Normalisation (CEN standard EN2) closely follows ISO standard 3941.

* Refer to the recommendations by the International Organization for Standardization, in particular Publication ISO 7165:1999, Fire-fighting - Portable fire extinguishers - Performance and construction.

6 Test specifications

6.1 Construction, performance and fire-extinguishing test specifications should be to the satisfaction of the Administration, having due regard to an established international standard*.

7 Criteria for assessing compliance with chapter 4 of the FSS Code and regulations V/20 and V/38 of the 1993 Torremolinos Protocol relating to the 1977 Torremolinos Convention

7.1 Chapter 4 of the FSS Code requires that extinguishers have a fire-extinguishing capability at least equivalent to that of a 9 L fluid extinguisher having a rating of 2A on class A fire which may be water or foam as required by the Administration. This equivalence may be demonstrated by fire test ratings determined according to an international, national or other recognized standard*.

7.2 The size and type of extinguishers should be dependent upon the potential fire hazards in the protected spaces while avoiding a multiplicity of types. Care should also be taken to ensure that the quantity of extinguishing medium released in small spaces does not endanger personnel.

8 Marking of extinguishers

8.1 Each extinguisher should be clearly marked with the following minimum information:

- .1 name of the manufacturer;
- .2 types of fire and rating for which the extinguisher is suitable;
- .3 type and quantity of extinguishing medium;
- .4 approval details;
- .5 instructions for use and recharge (it is recommended that operating instructions be given in pictorial form, in addition to explanatory text in language understood by the likely user);
- .6 year of manufacture;
- .7 temperature range over which the extinguisher will operate satisfactorily; and
- .8 test pressure.

Disclaimer : Although all possible efforts have been made to ensure correctness and completeness of the information contained in this Web Service, the Korean Register of Shipping is not responsible for any errors or omissions made herein, nor held for any actions taken by any party as a result of information retrieved from this Web Service.

E-mail : krcon@krs.co.kr

| | |
|--------------|---|
| Title | RESOLUTIONS / Assembly / 23rd Session / Res.A.951(23) |
| Note | Revokes Res.A.602(15) |

9 Periodical inspections and maintenance

9.1 Extinguishers should be subject to periodical inspections in accordance with the manufacturer's instructions and serviced at intervals not exceeding one year.

* Refer to the recommendations by the International Organization for Standardization, in particular Publication ISO 7165:1999, Fire-fighting - Portable fire extinguishers - Performance and construction.

9.1.1 At least one extinguisher of each type manufactured in the same year and kept on board a ship should be test discharged at five yearly intervals (as part of a fire drill).

9.1.2 All extinguishers together with propellant cartridges should be hydraulically tested in accordance with the recognized standard or the manufacturer's instruction at intervals not exceeding ten years.

9.1.3 Service and inspection should only be undertaken by, or under the supervision of, a person with demonstrable competence, based on the inspection guide in table 9.1.3.

9.2 Records of inspections should be maintained. The records should show the date of inspection, the type of maintenance carried out and whether or not a pressure test was performed.

9.3 Extinguishers should be provided with a visual indication of discharge.

9.4 Instructions for recharging extinguishers should be supplied by the manufacturer and be available for use on board.

| ANNUAL INSPECTION | |
|--|---|
| Safety clip and indicating devices | Check to see if the extinguisher may have been operated. |
| Pressure indicating device | Where fitted, check to see that the pressure is within limits. Check that dust covers on pressure indicating devices and relief valves are in place. |
| External examination | Inspect for corrosion, dents or damage which may affect the safe operation of the extinguisher. |
| Weight | Weigh the extinguisher and check the mass compared to the fully charged extinguisher. |
| Hose and nozzle | Check that hoses and nozzles are clear and undamaged. |
| Operating instructions | Check that they are in place and legible. |
| INSPECTION AT RECHARGE | |
| Water and foam charges | Remove the charge to a clean container if to be reused and check if it is still suitable for further use. Check any charge container. |
| Powder charges | Examine the powder for reuse. Ensure that it is free flowing and that there is no evidence of caking lumps or foreign bodies. |
| Gas cartridge | Examine for damage and corrosion. |
| INSPECTION AT FIVE AND TEN YEAR INTERVALS | |
| INSPECTION AFTER DISCHARGE TEST | |
| Air passages and operating mechanism | Prove clear passage by blowing through vent holes and vent devices in the cap. Check hose, nozzle strainer, discharge tube and breather valve, as applicable. Check the operating and discharge control. Clean and lubricate as required. |
| Operating mechanism | Check that the safety pin is removable and that the lever is undamaged. |
| Gas cartridge | Examine for damage and corrosion. Weigh the cartridge to ascertain that it is within prescribed limits. |
| O-rings washers and hose diaphragms | Check O-rings and replace hose diaphragms if fitted. |

Disclaimer : Although all possible efforts have been made to ensure correctness and completeness of the information contained in this Web Service, the Korean Register of Shipping is not responsible for any errors or omissions made herein, nor held for any actions taken by any party as a result of information retrieved from this Web Service.

E-mail : krcon@krs.co.kr

| | |
|--------------|---|
| Title | RESOLUTIONS / Assembly / 23rd Session / Res.A.951(23) |
| Note | Revokes Res.A.602(15) |

| | |
|----------------------------------|--|
| Water and foam bodies | Inspect the interior. Check for corrosion and lining deterioration. Check separate containers for leakage or damage. |
| Powder body | Examine the body and check internally for corrosion and lining deterioration. |
| INSPECTION AFTER RECHARGE | |
| Water and foam | Replace the charge in accordance with the manufacturers instructions. |
| Reassemble | Reassemble the extinguisher in accordance with the manufacturers instructions. |
| Maintenance label | Fill in entry on maintenance label, including full weight. |
| Mounting of extinguishers | Check the mounting bracket or stand. |
| Report | Complete a report on the state of maintenance of the extinguisher. |

Table 9.1.3 - Inspection guide

APPENDIX

| Extinguishing medium used: | TYPES OF EXTINGUISHER | | | | | | |
|---|--|---|------|---|--|---|--------------|
| | Water | | Foam | | Powder | Carbon dioxide | Clean agents |
| | Water, with possible salts in solution | | | Water solution containing foam generating substances | Dry chemical Powders | Pressurized carbon dioxide | |
| Expellant charge of the extinguisher (stored pressure or cartridge as indicated): | | Carbon dioxide or other pressurized inert gases or compressed air (stored pressure or separate cartridge) | | Carbon dioxide or other pressurized inert gases or compressed air (stored pressure or separate cartridge) | Carbon dioxide or other inert gases or dry air (stored pressure or separate cartridge) | | |
| The discharge of the extinguisher is achieved by: | | Opening of the valve. Action of pressurized gas (opening of the cartridge) | | Opening of the valve. Action of pressurized gas (opening of the cartridge) | Opening of the valve. Action of pressurized gas (opening of the cartridge) | Opening of the valve of the container constituting the extinguisher | |

| | |
|--------------|---|
| Title | RESOLUTIONs / Assembly / 23rd Session / Res.A.951(23) |
| Note | Revokes Res.A.602(15) |

| TYPES OF EXTINGUISHER | | | | | | | |
|---|---|----------|---|--|---|--|---|
| The discharged extinguishing medium consists of: | Water | | Foam | | Powder | Carbon dioxide | Clean agents |
| | Water with possible salts in solution | | | Foam containing the gas used | | Dry chemical powders and carbon dioxide or other gas | Carbon dioxide |
| The discharged extinguishing medium causes the extinction of the fire by: | Cooling of the burning materials. Water evaporation and consequent formation of a local atmosphere (water/steam) which isolates the burning products from the surrounding air | | Formation of a foam layer which isolates the burning products from the surrounding air and cooling in the case of class A fires | | Inhibition of the combustion process by the interrupting the chemical reaction. Some separation of burning materials from the surrounding air | Formation of a local inert atmosphere (carbon dioxide) which isolates the burning material from the surrounding air. Smothering and cooling action of carbon dioxide | |
| The electrical resistance of the discharged extinguishing medium is: | Very low | Very low | | Varied | Very high Under intense heat some powders may be electrically conductive | Very high | |
| TYPES OF EXTINGUISHER | | | | | | | |
| Operating peculiarities and limitations: | Water | | Foam | | Powder | Carbon dioxide | Clean agents |
| | The jet or spray of the extinguisher should be directed towards the base of the fire | | | The extinction of the fire achieved only when all the burning surface is covered by foam | | Powder mixture subject to windage, they may therefore have reduced effectiveness in the open or in ventilated spaces | Gas subject to windage, they therefore have limited effectiveness in the open or in ventilated spaces |

Disclaimer : Although all possible efforts have been made to ensure correctness and completeness of the information contained in this Web Service, the Korean Register of Shipping is not responsible for any errors or omissions made herein, nor held for any actions taken by any party as a result of information retrieved from this Web Service.

E-mail : krcon@krs.co.kr

| | |
|--------------|---|
| Title | RESOLUTIONS / Assembly / 23rd Session / Res.A.951(23) |
| Note | Revokes Res.A.602(15) |

| | TYPES OF EXTINGUISHER | | | | |
|-----------------------------------|---|------|--|---|--------------|
| | Water | Foam | Powder | Carbon dioxide | Clean agents |
| Disadvantages and dangers: | Not to be used where there is electrical hazard | | Generated powder mixtures may be suffocating and can impair vision. Powder can damage electrical contact. | Carbon dioxide may be suffocating | |
| Maintenance: | Extinguishers with copper or copper alloy body should not be polished with products of corrosive or abrasive nature which may cause wall thickness reduction. Such extinguishers should be avoided but where used they should preferably be painted externally. | | Some types of powder may be altered by humidity, therefore, avoid the refilling of the extinguisher in humid locations. | | |
| | The charge can freeze at temperatures of about 0°C (unless the charge is made non-freezable chemically) | | The charge can freeze at about 5°C. The charge can be altered by elevated temperatures (about 40°C or more). Therefore, the extinguisher should not be installed in positions where it may be exposed to high or low temperatures. | When a carbon dioxide container is provided, avoid the installation of the extinguisher in excessively warm locations, where the internal pressure of the carbon dioxide in the container might rise to very high values. | |
| | Avoid installing the extinguisher in excessively warm locations, where the internal pressure of the carbon dioxide in the cartridge might rise to a very high value | | | | |

KOREAN REGISTER

Disclaimer : Although all possible efforts have been made to ensure correctness and completeness of the information contained in this Web Service, the Korean Register of Shipping is not responsible for any errors or omissions made herein, nor held for any actions taken by any party as a result of information retrieved from this Web Service.

E-mail : krcon@krs.co.kr

4 ALBERT EMBANKMENT
LONDON SE1 7SR
Telephone: +44 (0)20 7735 7611 Fax: +44 (0)20 7587 3210

MSC.1/Circ.1516
8 June 2015

**AMENDMENTS TO THE REVISED GUIDELINES FOR THE MAINTENANCE
AND INSPECTION OF FIRE PROTECTION SYSTEMS AND APPLIANCES
(MSC.1/CIRC.1432)**

1 The Maritime Safety Committee, at its ninety-fifth session (3 to 12 June 2015), approved amendments to the *Revised guidelines for the maintenance and inspection of fire protection systems and appliances* (MSC.1/Circ.1432), as set out in the annex, concerning testing of automatic sprinkler systems, prepared by the Sub-Committee on Ship Systems and Equipment, at its second session.

2 Member Governments are invited to use the amendments when applying MSC.1/Circ.1432 and to bring the amendments to the attention of ship designers, shipyards, shipowners, systems manufactures and all parties concerned.

ANNEX

AMENDMENTS TO THE REVISED GUIDELINES FOR THE MAINTENANCE AND INSPECTION OF FIRE PROTECTION SYSTEMS AND APPLIANCES (MSC.1/CIRC.1432)

- 1 Paragraph 3.4 is amended to read as follows:

"3.4 In addition to the onboard maintenance and inspections stated in these guidelines, manufacturer's maintenance and inspection guidelines should be followed. The quality of water in automatic sprinkler systems is of particular importance and should be maintained in accordance with manufacturer guidelines. Records of water quality should be maintained on board in accordance with the manufacturer's guidelines."

- 2 A new paragraph 6.5 is added after the existing paragraph 6.4, as follows:

"6.5 Water mist, water spray and sprinkler systems

Assess system water quality in the header tank and pump unit against the manufacturer's water quality guidelines."

- 3 Paragraph 7.5 is amended to read as follows:

"7.5 Water mist, water spray and sprinkler systems

- .1 verify proper operation of all water mist, water-spray and sprinkler systems using the test valves for each section;
- .2 visually inspect all accessible components for proper condition;
- .3 externally examine all high pressure cylinders for evidence of damage or corrosion;
- .4 check the hydrostatic test date of all high pressure cylinders;
- .5 functionally test all fixed system audible and visual alarms;
- .6 flow test all pumps for proper pressure and capacity;
- .7 test all antifreeze systems for adequate freeze protection;
- .8 test all system cross connections to other sources of water supply for proper operation;
- .9 verify all pump relief valves, if provided, are properly set;
- .10 examine all filters/strainers to verify they are free of debris and contamination;
- .11 verify all control/section valves are in the correct position;

- .12 blow dry compressed air or nitrogen through the discharge piping of dry pipe systems, or otherwise confirm the pipework and nozzles are clear of any obstructions. This may require the removal of nozzles, if applicable;
- .13 test emergency power supply switchover, where applicable;
- .14 visually inspect all sprinklers focusing in areas where sprinklers are subject to aggressive atmosphere (like saunas, spas, kitchen areas) and subject to physical damage (like luggage handling areas, gyms, play rooms, etc.) so that all sprinklers are inspected within one year. Sprinklers with obvious external damage, including paint, should be replaced and not included in the number of sprinklers tested in subparagraph .17;
- .15 check for any changes that may affect the system such as obstructions by ventilation ducts, pipes, etc.;
- .16 test a minimum of one section in each open head water mist system by flowing water through the nozzles. The sections tested should be chosen so that all sections are tested within a five-year period;
- .17 test automatic sprinklers and automatic water mist nozzles in accordance with the following flow chart:

Part 1 - Basic Testing

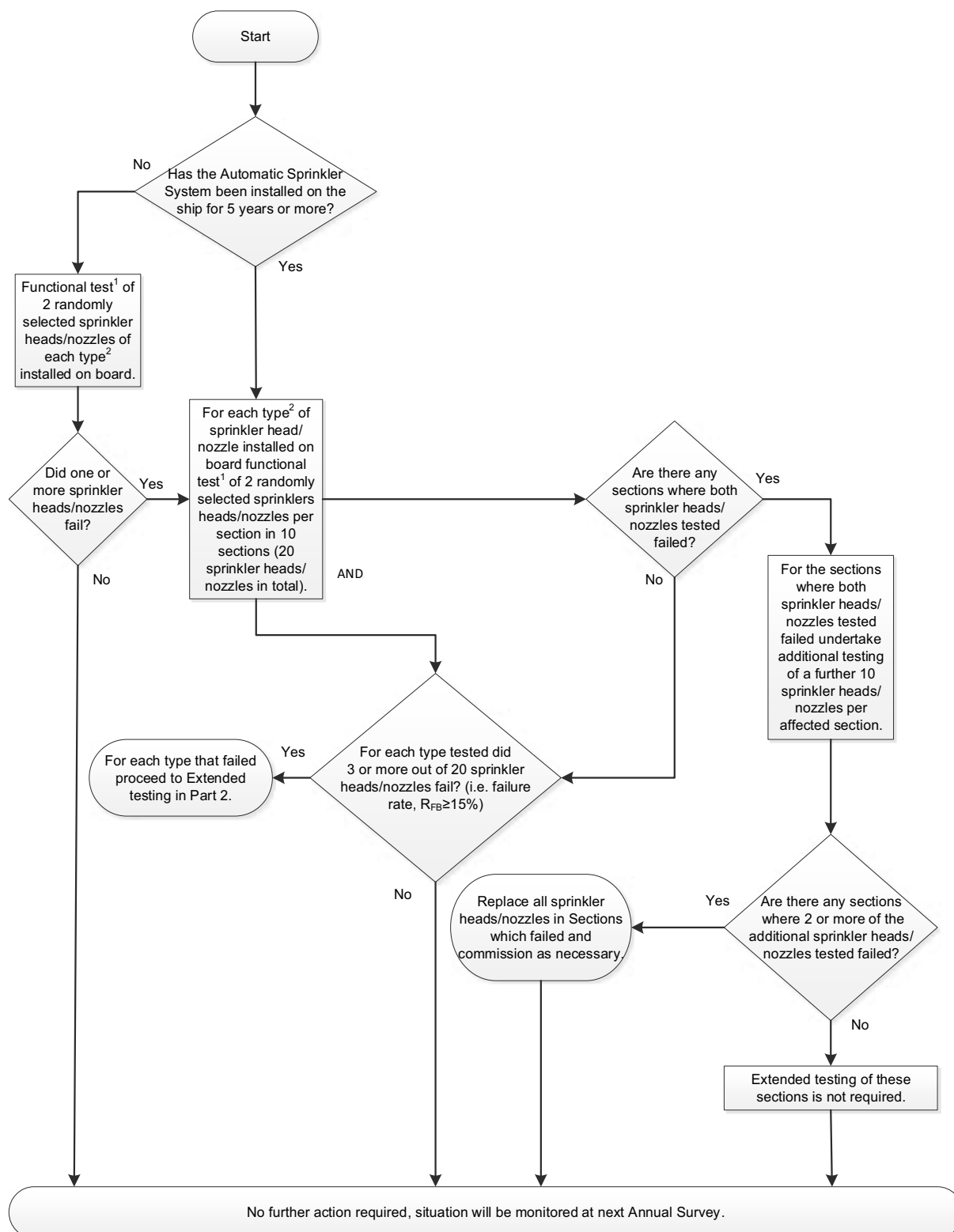

Part 2 - Extended testing

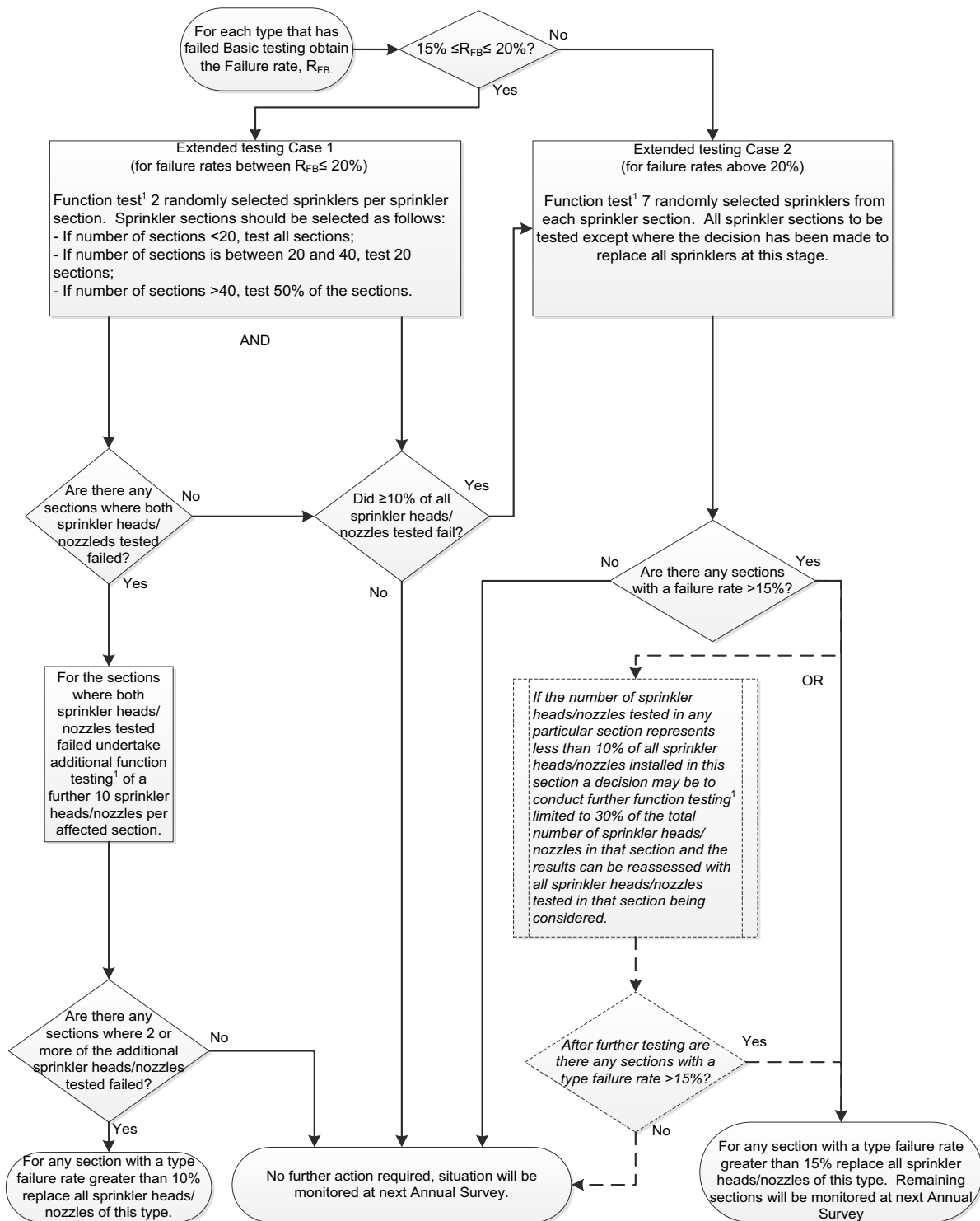

Explanatory notes to the flow chart

- 1 *Functional test* is defined as a test that demonstrates the operation and flow of water from sprinkler head/nozzle.
 - 2 *Type* is defined as each different manufacturer model of sprinkler head/nozzle.
 - 3 *Static/standby pressure* is defined as the constant pressure maintained in the system at all times prior to activation.
 - 4 All testing should be carried out at static/standby pressure.
 - 5 *Failure rate* (R_{FB}) is the number of sprinkler heads/nozzles to fail testing divided by test sample size multiplied by 100; and
- .18 during basic testing, and extended testing when applicable, of automatic sprinkler heads/nozzles as outlined in subparagraph .17, water quality testing should be conducted in each corresponding piping section. Note – should a tested sprinkler fail, assessing the corresponding water quality at that time would assist in determining the cause of failure."
- 4 Paragraph 9.3 is replaced by the following:
- "9.3 Water mist, water spray and sprinkler systems
- .1 flush all ro-ro deck deluge system piping with water, drain and purge with air;
 - .2 perform internal inspection of all control/section valves; water quality testing should be conducted in all corresponding piping sections, if not previously tested as outlined in paragraph 7.5.18 within the last five years;
 - .3 check condition of any batteries, or renew in accordance with manufacturer's recommendations; and
 - .4 for each section where the water is refilled after being drained or flushed, water quality should meet manufacturer's guidelines. Testing of the renewed water quality should be conducted and recorded as a new baseline reference to assist future water quality monitoring for each corresponding section."
-